

MIDLAND LMR

LAND MOBILE RADIO



SERVICE MANUAL 70-1336A/B

MOBILE TRANSCEIVER
VHF HIGH BAND
(136-160 MHz, 150-174 MHz)
15-30 WATT

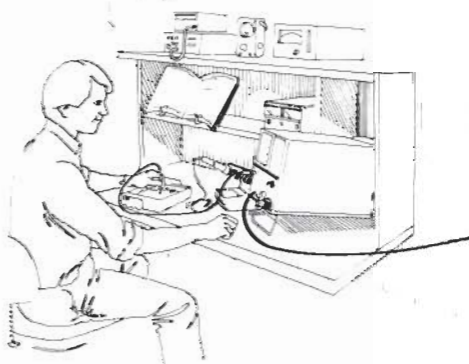
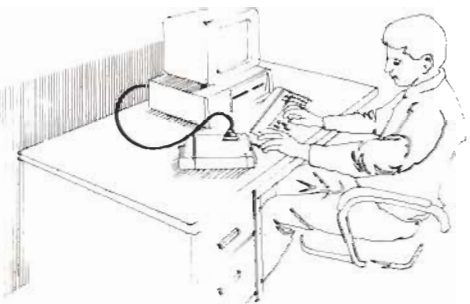

MANUAL NO.: 70-133600
09-1336-SM-4/91-2M

This manual section is designed to facilitate the set-up and service of the Midland 70-1336 transceivers. As necessary, service manual supplements will be published and distributed on the following forms:

Manual Addition (MA) For supplemental information useful in product service or improvement. Printed on BLUE paper.

Change Notice (CN) For details about changes made during production by model and serial number. Printed on YELLOW paper.

Manual Correction (MC) For correcting literature errors not related to production changes. Printed on GREEN paper.

Technical Bulletin (TB) For solutions to field problems and tips for performance improvement. Printed on PINK paper.

Comments or suggestions concerning areas of manual improvement are welcome.

TABLE OF CONTENTS

Manual Supplement Information	ii
Table of Contents	iii
SECTION 1	GENERAL INFORMATION
Description	1 - 3
Specifications	1 - 3
SECTION 2	PREPARATION
Pre-Installation Check	2 - 3
Complete Realignment	2 - 3
SECTION 3	INSTALLATION
Installation	3 - 3
SECTION 4	SERVICING
Component Replacement	4 - 3
Eliminating Radio Interference	4 - 7
Voltage Charts	4 - 11
Troubleshooting Charts	4 - 14
SECTION 5	CIRCUIT DESCRIPTIONS
RF Section	5 - 3
30-Watt PA Section	5 - 5
Logic Section	5 - 5
SECTION 6	DIAGRAMS
Block Diagram	6 - 3
Wiring Diagram	6 - 4
CX-103 Layout	6 - 4
CX-104 Layout	6 - 4
TR-1519 Layout — Bottom View	6 - 5
TR-1519 Layout — Top View	6 - 6
TR-1519 Schematic	6 - 7
Component Layout	6 - 8
Diode Pinouts	6 - 9
Transistor Pinouts	6 - 9
Exploded View	6 - 10
SECTION 7	PARTS
Parts List	7 - 3
Replacement Parts Ordering	7 - 10

SECTION 1 — General Information

1

SECTION 2 — Preparation

2

SECTION 3 — Installation

3

SECTION 4 — Servicing

4

SECTION 5 — Circuit Descriptions

5

SECTION 6 — Diagrams

6

SECTION 7 — Parts

7

SECTION 1

GENERAL INFORMATION

DESCRIPTION

The 70-1336 Midland 8-Channel Wide Band transceivers are programmable frequency-synthesized two-way FM mobile radios that operate in the high-band VHF frequency range. They are programmable for up to eight channels.

The 70-1336 is designed to operate within either of two frequency ranges: 136—160 MHz (A-Band), or 150—174 MHz (B-Band). Transmit RF power is adjustable for 15—30 Watts.

1**SPECIFICATIONS**

Refer to EIA-152-C, EIA/TIA-204-D, EIA-220-B, and DOC RSS-119 for standard of performance and method of measurement.

GENERAL**OPERATING FREQUENCY RANGE:**

A-Band: 136—160 MHz

B-Band: 150—174 MHz

CHANNEL SEPARATION: 24 MHz**CHANNEL SPACING:** 30 kHz**CHANNEL STEPPING:** 2.5 kHz**CHANNEL CAPACITY:** Programmable for up to eight channels**POWER SUPPLY:** 13.6 V DC negative to ground**CURRENT DRAIN:**

Transmit (at 30 W): 8.0 A

Receive (@ rated audio): 2.0 A

Standby (std, varies with options): 400 mA

OPERATING TEMPERATURE: -30° C + 60° C**DIMENSIONS (H x W x D):** 2 x 7 x 8⁷/₈ in (50 x 178 x 225 mm)**WEIGHT:** 2.5 kg

GENERAL INFORMATION

70-1336

TRANSMITTER

- RF POWER OUTPUT (adjustable):** 15—30 W
- FREQUENCY STABILITY:** $\pm 0.0005\%$ ($-30^{\circ}\text{C} + 60^{\circ}\text{C}$)
- MODULATION (FOR 100% AT 1000 Hz):** 16K0F3E ± 5.0 kHz @ 25/30 kHz
- BANDWIDTH:** 24 MHz without retuning
- SPURIOUS AND HARMONICS:** -61 dB
- FM HUM AND NOISE:** -50 dB
- AUDIO RESPONSE:** per EIA and DOC specifications
- AUDIO DISTORTION (± 3 kHz deviation):** Less than 3% @ 1 kHz
- OUTPUT IMPEDANCE:** $50\ \Omega$

RECEIVER

- FREQUENCY STABILITY:** $\pm 0.0005\%$ ($-30^{\circ}\text{C} + 60^{\circ}\text{C}$)
- SENSITIVITY:**
12 dB SINAD: $0.30\ \mu\text{V}$
20 dB Quieting: $0.5\ \mu\text{V}$
- SELECTIVITY:** -80 dB @ ± 30 kHz
- BANDWIDTH:** 24 MHz without retuning
- ACCEPTABLE RADIO FREQUENCY DISPLACEMENT:** ± 3.5 kHz
- SPURIOUS REJECTION:** -80 dB
- INTERMODULATION:** -78 dB
- SQUELCH SENSITIVITY:** $0.2\ \mu\text{V}$ maximum
- AUDIO OUTPUT:**
Internal Speaker: 2 W @ less than 3% distortion @ $8\ \Omega$
External Speaker: 5 W @ less than 3% distortion @ $3.2\ \Omega$
- INPUT IMPEDANCE:** $50\ \Omega$

CTCSS/DCS

OPERATING TEMPERATURE RANGE: -30° C — +60° C

CTCSS TONES: All EIA tones from 67.0 Hz to 250.3 Hz, plus 97.4 Hz

DCS CODES: All codes from 000 to 777, normal and invert

ENCODE TONE/DCS MODULATION LEVEL: 500 Hz — 1000 Hz deviation

ENCODER RESPONSE TIME: CTCSS/DCS 50 ms max

ENCODER TONE DISTORTION (67 Hz—250.3): 3% max

TONE/SQUELCH OPENING SINAD: 8 dB max

HUM AND NOISE: 32 dB

DECODER RESPONSE TIME:

CTCSS: 200 ms max (for tones above 100 Hz)

DCS: 324 ms max

— Specifications subject to change without notice —

SECTION 2

PREPARATION

PRE-INSTALLATION CHECK

The 70-1336 TX/RX Units are capable of operating across a 24 MHz frequency spread and do not require optimizing alignment, even when reprogrammed with new customer frequencies. Only general transmitter/receiver performance should be checked. Complete realignment may be necessary after a component that affects transceiver tuning has been replaced. Either the 70-1080A Programmer or 70-1489 PC Programming software (with 70-1308A programming interface) may be used.

SET-UP

1. Remove the PWR/VOL knob. Using a flat blade screwdriver, carefully pry the unit cover outward at the slots marked "RELEASE" near the rear of each side. Lift the cover from the chasis, starting at the back.
2. Connect a resistive, 50-Ω RF load (with a wattmeter) to Antenna Connector J501. Connect 13.6 V DC power to J415. Turn the radio on, turn MON on, and turn selective signaling options off.

CARRIER FREQUENCY

1. Initiate transmit on any channel. Measure transmitted RF carrier frequency without modulation and, if needed, set carrier frequency to within ±400 Hz of channel frequency using the programmer (either the 70-1080A programmer or 70-1489 software).

2. Initiate transmit on any channel. Measure power of RF output at 50-Ω Antenna Connector J501. Adjust RV402 to obtain 30 W RF output power.

MAXIMUM DEVIATION

1. Select a channel with a transmit frequency of 136 MHz for A-Band, or 150 MHz for B-Band. If CTCSS or DCS is used, be sure this channel is programmed to send the same.
2. Disconnect the hand microphone from its front panel receptacle J301. Apply 3 V_{rms} of 1000 Hz signal to pin 1 of Mic Jack J301, then initiate transmit by grounding pin 4. Make sure total carrier deviation is below ±5 kHz (including CTCSS/DCS signal). If adjustment is needed, see MODULATOR ALIGNMENT on page 2 - 4.

COMPLETE REALIGNMENT

Complete realignment is needed only if a component that affects alignment has been replaced. RADIO REPROGRAMMING WITH TEST FREQUENCIES IS REQUIRED.

SET-UP

1. Remove the PWR/VOL knob. Using a flat blade screwdriver, carefully pry the unit cover outward at the slots marked "RELEASE" near the rear of each side. Lift the cover from the chasis, starting at the back.
2. Connect a resistive 50-Ω RF load and wattmeter to Antenna Connector J501. Connect 13.6 V DC power to transceiver J415.
3. Connect a 3.2-Ω, 20-W resistor to pins 4 and 6 of the Accessory Plug. The jumper between pins 5 and 6 must be temporarily removed to make this connection. The resistor serves as a constant load to replace the speaker's inconsistencies.

CAUTION: Both speaker terminals are LIVE. Never ground either one. Connect grounded receive-audio measuring equipment to only one side of the speaker, and chassis ground. Normally, voltage measurement will be half of true values.

4. Turn the radio on, set the VOLUME control to a mid-position.
5. Connect the programmer (the 70-1080A or 70-1308A interface) to Programming Port J402. Upload the radio programming Data-Packet into the Programmer and initiate its Remote Control Mode. Refer to the appropriate manual for details.

PREPARATION

70-1336

SYNTHESIZER ALIGNMENT

• VCO Resonance

1. Select the Remote-Control mode of the programmer. For A-Band models, enter a test frequencies of 136.00 MHz for both RX and TX. For B-Band models, enter a test frequency of 150.00 MHz.
2. Adjust Channel RX Tank L713 for 1.5 V DC at CM701 pin 2 (VCO steering).
3. Activate transmit mode (using the programmer) and adjust transmitter VCO L733 for 1.5 V DC at CM701 pin 2.

• Reference Oscillator

4. Initiate transmit on any channel. Measure transmitted RF carrier frequency without modulation and, if needed, adjust the carrier frequency and bring the radio to within ± 400 Hz of operating frequency.

30 W PA SECTION ALIGNMENT

1. Change the TX test frequency to the desired frequency.
2. Activate transmit mode, then adjust CV501 to obtain maximum RF power at Antenna Connector J501.
3. Set RF output power to 30 W using RV402.

MODULATOR ALIGNMENT

• Modulation Limiting

1. Disconnect the hand microphone from its front panel receptacle J301. Apply 3 V_{rms} of 1000 Hz signal to pin 1 of Mic Jack J301, then initiate transmit (if not using a programmer, ground J301 pin 4).
2. Measure total carrier deviation and, if needed adjust modulation limiting to obtain ± 5 kHz using RV403.

• Microphone Gain

3. No alignment for Microphone gain is required.

• CTCSS/DCS

4. Remove the 1 kHz audio signal from external mic jack.
5. Add DCS code +023 to the transmit test mode testing frequency in the programmer.
6. Adjust RV1 for 750 Hz ± 10 Hz deviation.
7. Adjust RV401 so that modulation waveform from modulation analyzer matches the correct waveform shown in **Figure 2 - 1**.
8. Change the transmit test code in the programmer to 250.3 Hz CTCSS tone. Carefully adjust RV401 for 750 Hz ± 10 Hz deviation.
9. Change the transmit test code in the programmer to 67.0 Hz CTCSS tone. Carefully adjust RV1 for 750 Hz ± 10 Hz deviation.

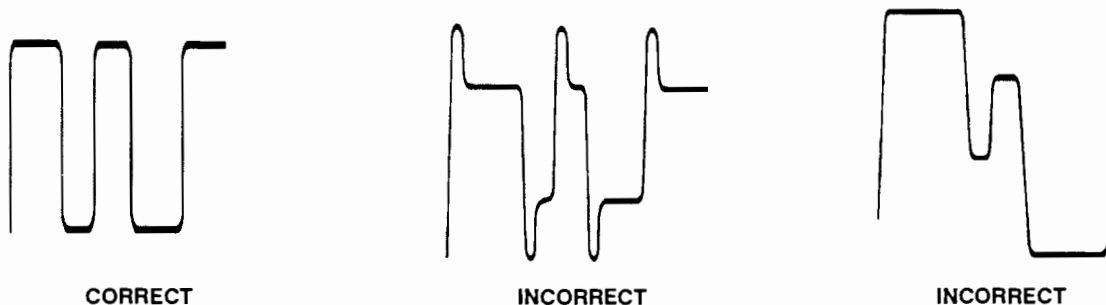

Figure 2 - 1 — Modulation Waveforms

RECEIVER

1. Change the RX test frequency to 148.20 MHz for A-Band radios, or 162.30 MHz for B-Band.

• **First Injection**

2. No adjustment for the first injection is needed.

• **Preselector Alignment**

3. No adjustment for the preselector (L201, L202, L203, L204, L205 and L206) is required.

• **Quadrature Detector**

4. Apply 1 mV of modulated (by 1 kHz tone at ± 3 kHz deviation) on-channel RF signal to Antenna Jack J501. Adjust Detector L250 for maximum audio output.

• **First I.F.**

5. Apply enough modulated (by 1 kHz tone at ± 3 kHz deviation) on-channel carrier to maintain 12 to 15 dB SINAD. Adjust L245—L247.

• **Squelch**

6. Set the left side Squelch switch on. Set Squelch Range RV241 fully clockwise.
7. Apply 0.2 μ V of unmodulated on-channel RF signal to the 50 Ω antenna connector. Adjust Squelch range RV241 counter-clockwise just until squelch opens (audio on).

Table 2 - 1 — Required Test Equipment

TEST INSTRUMENT	INSTRUMENT CAPABILITIES	USE
Regulated DC Power Supply	13.6 V DC, 10 A adjustable voltage	Radio power source
RF Wattmeter for 70-1336	50 W, 136—174 MHz 50- Ω circuit	Transmitter power measurements
RF Load Resistor	50- Ω ; 50 W	Antenna dummy load
Frequency Modulation Meter	136—174 MHz; peak - responding, ± 5 kHz range	Modulation level measurements
Frequency Meter or Frequency Counter	136—174 MHz 1.0 ppm accuracy	Carrier frequency measurements
Audio Generator	1000 kHz sine-wave; 0—4 V_{rms} output	Modulation level measurements
RF Signal Generator	136—174 MHz range; 0.1—1 μ V output; ± 3 kHz FM mod. with 1 kHz tone	All receiver measurements
Distortion Analyzer	1 kHz notch; 1% measuring range	Receiver performance test and IF alignment
Load Resistor (audio)	3.2- Ω , 20 W	Speaker load for all receiver measurements
AC Voltmeter	10 mV to 10 V_{rms}	Audio level adjustments
Oscilloscope	DC to 500 kHz bandwidth	
Digital Multimeter	0.1 to 20 V DC	Test point measurements and power supply set-up
70-1080A Programmer, or 70-1489 PC Programming software and 70-1308A PC Programming interface		Manual radio control

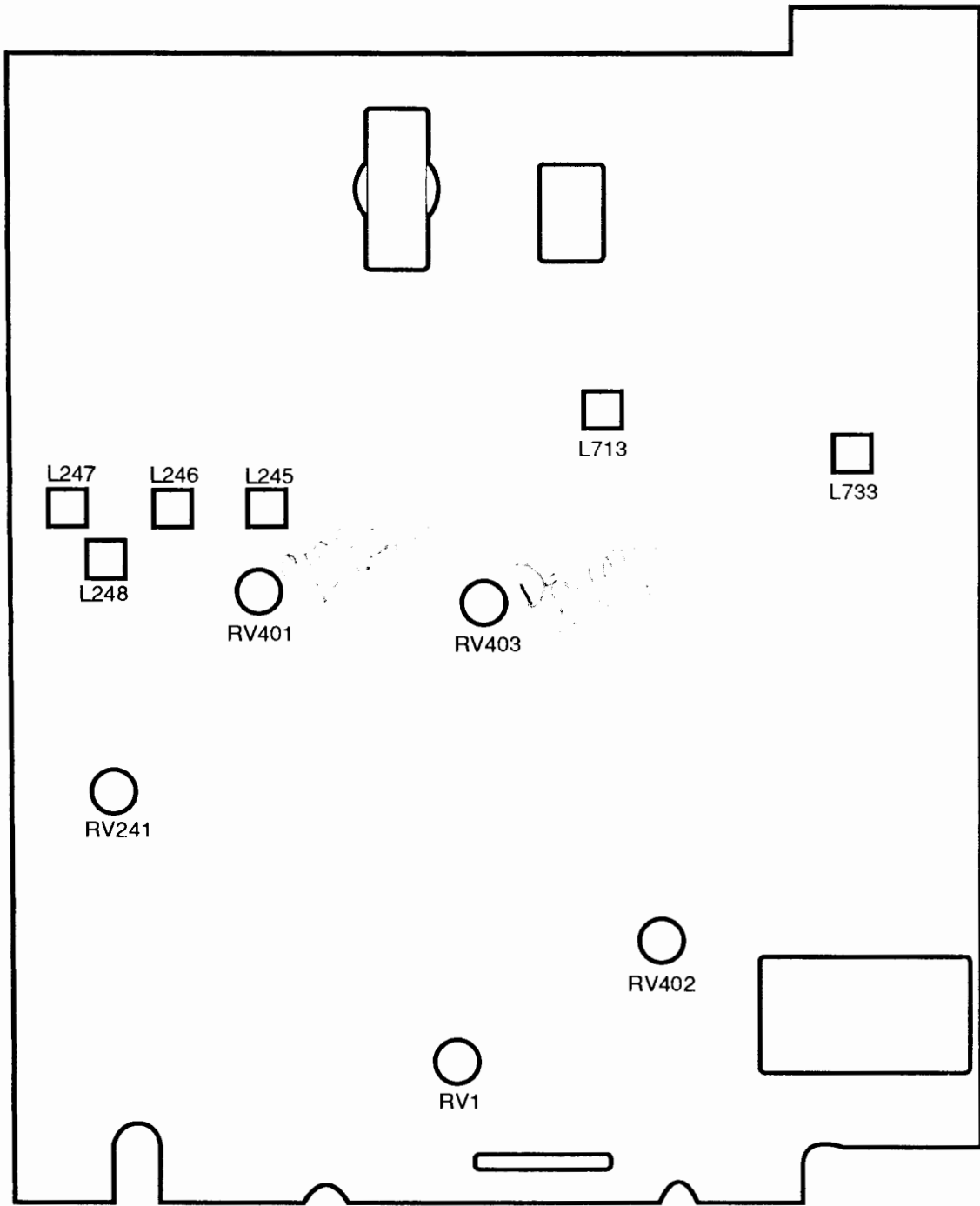

Figure 2 - 2 — Adjustment Map

SECTION 3

INSTALLATION

INSTALLATION

MOUNTING

The 70-1336 mounting bracket bolts onto the transceiver sides. It provides a 2.25" x 7.00" flat surface across the transceiver top, with holes for bolting to a even surface in the vehicle. 5/32" holes must be drilled in the mounting surface to accept the four 3/8" screws and washers provided.

POWER

• Connections

The 70-1311 Power/Accessory Cable is equipped with two unterminated 14 gauge wires two meters in length for connection to the vehicle electrical system.

Connect the black wire to the negative (-) chassis ground of the vehicle. **DO NOT ATTEMPT TO INSTALL THE TRANSCEIVER IN A POSITIVE GROUND VEHICLE.** A large bolt that screws into the metallic vehicle body or chassis often provides an adequate ground if a lug is used to secure the wire to it.

Connect the red wire to the positive (+) side of the vehicle electrical system. Because of current requirements, connection to an existing fused circuit should be avoided to prevent overload of that fuse. This wire has its own in-line fuse for protection against wire penetration and transceiver defect. The connection can be made to the ignition hot so that the transceiver switches on with ignition, or it can be made to battery hot to enable the last-selected-feature of the transceiver (the transceiver must be turned off separately). Either connection is usually available in the vehicle fuse block if the red transceiver wire is terminated with an appropriate lug.

• Requirements

The 70-1336 transceiver is designed to operate from a 12 V DC negative ground automotive electrical system. Current drain of at least 10 A should be

expected. Inspection of the vehicle is recommended prior to installation. A low battery or other electrical system defects may degrade transceiver performance.

CAUTION: Check the voltage source before connecting the power cable. Too much voltage (above 16 V) can severely damage the transceiver.

The transceiver is shipped with a 2 m Power/Accessory cable. Each cable includes fused power leads for connection to the vehicle electrical system. Because the transceiver chassis is connected to the negative (-) lead, **DO NOT INSTALL THE TRANSCEIVER IN A POSITIVE GROUND VEHICLE.** If the transceiver is used as a base station, the external AC-line-to-DC power supply must be adequately regulated and have sufficient current capacity.

ANTENNA

The communications system component that can affect overall performance the most is the antenna. A good quality antenna designed to provide 50 Ω terminating impedance at appropriate transceiver frequencies is recommended. When adjusting the antenna, be sure to follow its manufacturer's instructions. A better quality SWR meter should be used to accurately measure minimum reflected energy.

MICROPHONE HANGER

The hand microphone included with the transceiver has a button on its backside to mate with its hang-up clip. The clip must be mounted with three screws in a location convenient to the operator. Three 1/2" screws and three 3/4" screws, each requiring a 5/64" hole, are also provided.

An optional microphone hanger (model 70-2195) is available for use with the CTCSS option. This hang-up box may be installed in place of the microphone clip on both metallic or non-metallic surfaces.

INSTALLATION

70-1336

POWER ACCESSORY PLUGS

A 10-pin male Molex connector and a fused, 2 m power cable assembly (70-1311), mates to the power/accessory connector (J415) on the rear of the 70-1336. Extra pin positions are used for connection of optional devices not included with this assembly.

Optional devices can be connected to the Power/Accessory Plug by inserting Molex pins included with these devices into their respective vacant holes. See **Figure 3 - 1**. Option connections are shown in lighter shade.

EXTERNAL SPEAKER

Normally, the transceiver internal speaker is connected to receive audio by the jumper to pins 5 and 6. If one of the MIDLAND external speakers is to be utilized, the jumper must be removed to dis-

able the internal speaker and the two wires from the external speaker must connect to pin 4 and 6.

NOTE: If the 70-2355 15 W External Speaker is to be connected, its input cable center conductor (white) must be connected to pin 6, and the shield (black) to pin 4.

HANG-UP BOX (Optional)

The 70-2195 Microphone Hang-Up contact/switch-box is installed to unmute CTCSS/DCS squelch when the microphone is lifted. The center conductor of the shielded hang-up box cable connects to pin 3, the shield to pin 2.

AUXILIARY DEVICES

Pins 1 and 8 are available for auxiliary connections necessary with certain optional features. Wiring details for these are found in the literature for the option.

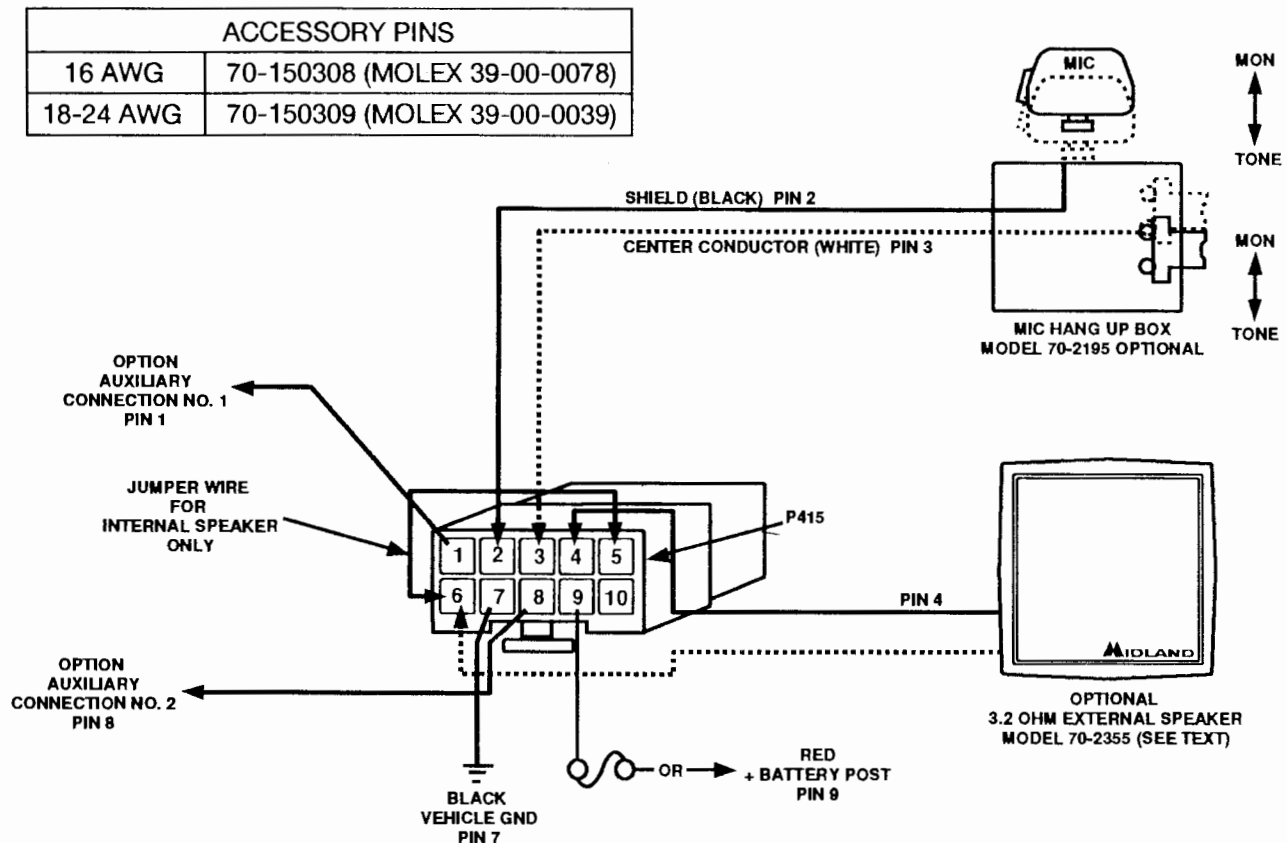

Figure 3 - 1 — Power and Accessory Plugs

SECTION 4

SERVICING

WHITE TO P.W 6

SC20400 B

Rx

REMOVE " UNSOLDER NEGATIVE LEAD OF C 59
SOLDER (GREEN) Audio Rx INPUT TO ^{RESISTOR} NEGATIVE side of
CAPACITOR. SOLDER (BLUE) WIRE RX OUT TO HOLE LEFT
BY CAPACITOR NEGATIVE LEAD.

REMOVE JP9 CHIP RESISTOR

TX (ORANGE) WIRE TO CHIP RESISTOR SIDE NEXT TO SHIELD
YELLOW TO OTHER SIDE OF REMOVED CHIP RESISTOR

JP9

PTT

(GRAY)

PTT TO JP8 EITHER SIDE

B+

(Red)

JP408 # 6 = 9V

COMPONENT REPLACEMENT

STATIC POTENTIALS

Many of the transceiver components are susceptible to higher voltages whether they are in or out of a circuit. Avoid static or AC-line potentials when handling components and circuit boards. Prevent damage from electrically "hot" tips that carry AC-line or static potential by using a grounded soldering iron. The only way to alleviate risk of component damage from static discharge is to make sure all of the objects that touch the circuitry during component replacement carry the same potential. Since the soldering iron is grounded, everything else must be grounded: the bench, the equipment being worked on, and you. There usually isn't a need to wire yourself to your bench unless you work on carpeting on dry-air days. Just touch bench ground when you sit down so that you and the grounded work area are at the same potential.

REPLACING CHIP CAPACITORS AND RESISTORS

This section describes the best way to remove a chip component and install a new one. Chip components do not have leads; they have metallic film on end-surfaces to solder to. Often the surface is tinned with solder. Because the metallic film can be easily damaged by contamination and excessive heat, these components must be soldered very carefully. No chip component can be unsoldered, then resoldered without damage. Always discard a used component.

4

• ITEMS REQUIRED:

- Grounded temperature-controlled soldering iron with a 1/32 inch flat-blade tip. The tip temperature must be maintained at approximately 600 degrees Fahrenheit.
- 60/40 electronics-grade solder, 22 gauge or thinner, with rosin flux.
- Tweezers or longnose pliers.
- Thin desoldering-wick.
- Isopropyl alcohol or Freon-TF for solvent.
- Rosin solder-flux. DO NOT USE ACID FLUX.

SERVICING

70-1336

• **Procedure:**

1. Place the solder iron tip directly on the defective component to melt the glue under the component, then solder as shown in **Figure 4 - 1**. Remove the component with tweezers or longnose pliers. Discard the component.

CAUTION: Application of too much solder can create solder bridges between PC patterns under the soldered component and around the pad.

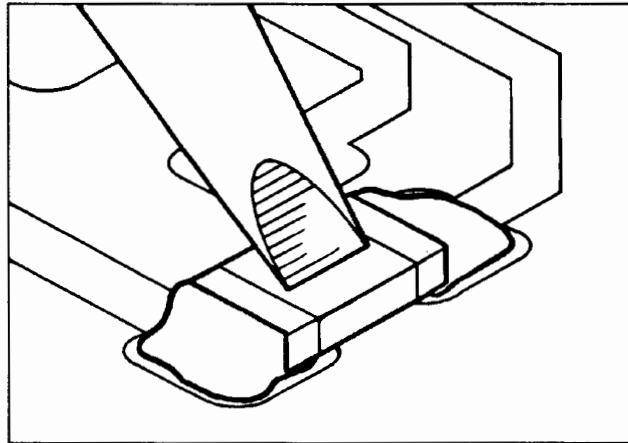

Figure 4 - 1

2. Completely remove old solder, old glue, and any other contaminants from the area with desoldering-wick and solvent.
3. Apply only enough fresh solder to coat the clean PC pad as shown in **Figure 4 - 2**.

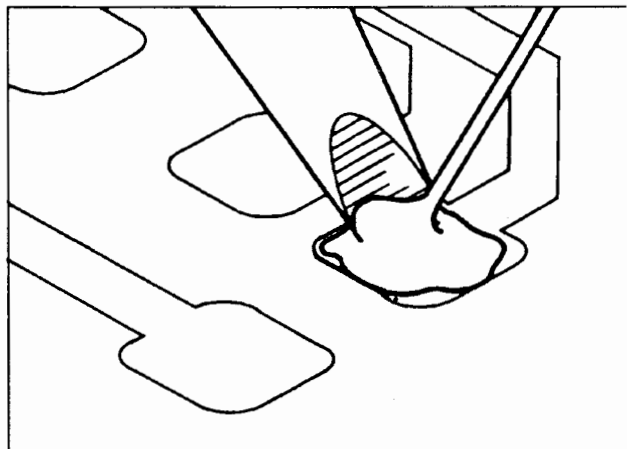

Figure 4 - 2

REPLACING COMPONENTS WITH FEED-THROUGH LEADS

Exercise extreme care when replacing components with leads that feed through a PC board. The copper plating on both sides of the printed circuit board and inside component lead holes easily separates and tears from the PC board when heated.

Use a solder suction tool or braided desoldering-wick to remove solder from component leads, one at a time. Solder must be removed carefully and thoroughly so that the IC can be pulled without resistance. After removing as much solder as possible, use a dental pick or straight-pin to break the leads loose from the inside of the cleaned-out hole. Cutting the defective components away from its leads first makes removing the leads and solder easier.

Before installing a new component, remove all solder from lead holes and make sure the device is oriented properly. Always inspect old part leads for any feed-through plating rings that may have been pulled out of holes. The plating may have completed a circuit. If so, make sure the corresponding lead of the new component is soldered to plating runners on both sides of PC board as shown below.

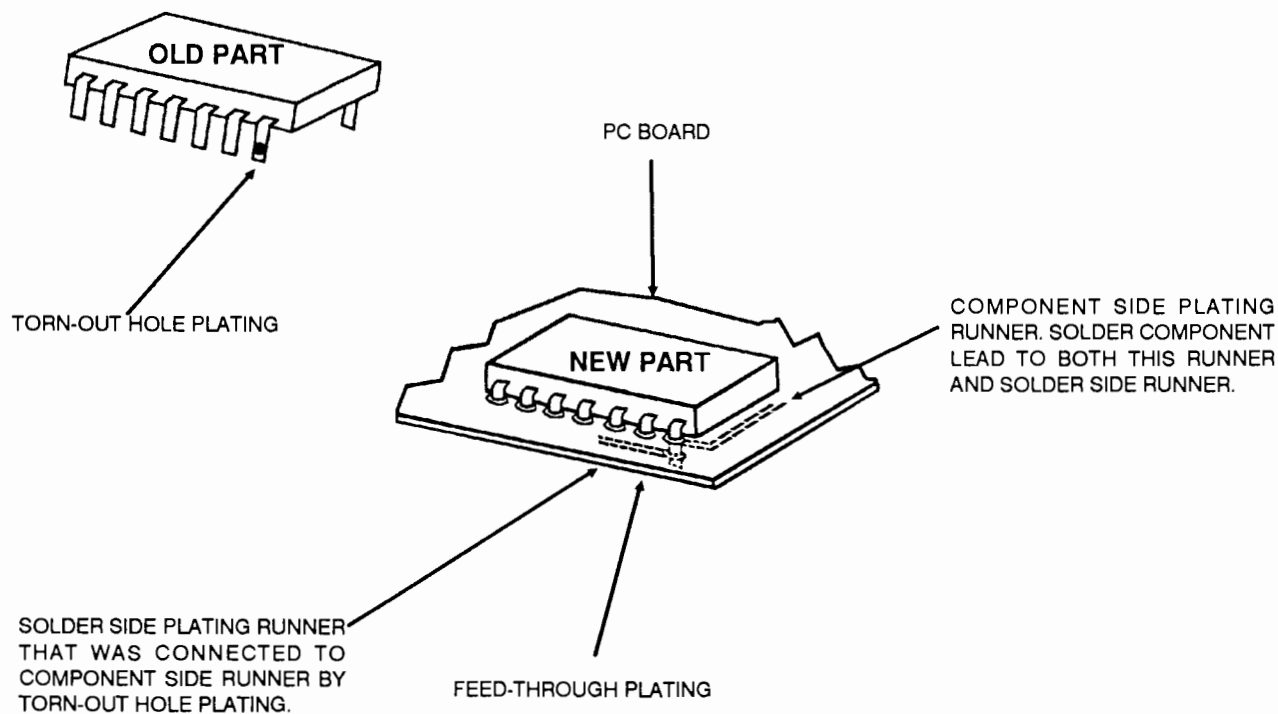

Figure 4 - 6

ELIMINATING RADIO INTERFERENCE

Occasionally, you must contend with interference from somewhere in the automobile. Interference problems are solved by understanding the interference and its path into the transceiver, locating its source logically, then eliminating it in the simplest way available.

Interference may be conducted into the transceiver directly, or induced into it, or both. Conducted interference passes through the DC power leads or the accessory wiring of the radio. Radiated interference, which can originate from anywhere in the vehicle, simply produces noise voltages on conductors inside the radio or its antenna. See **Figure 4 - 7**.

Conducted interference is simple noise voltage present in the vehicle electrical system. With many electrical devices turning on and off in a vehicle, current spikes produce voltage drops across wire resistances, causing voltage transients to appear throughout the electrical system. Connecting the radio power leads to this noisy electrical system applies the noise voltage directly to the radio. Most noise voltage is attenuated by power-line filters within the radio; but spikes that are severe enough may become audible.

While interference conducted through power leads affects only transceiver audio circuitry, induced interference often invades the receiver through the antenna by imitating receiver IF frequencies or channel frequencies. Induced interference occurs when an electromagnetic field penetrates the radio. If an electromagnetic field is strong enough, it can induce noise currents on the radio accessory and power wiring.

IDENTIFYING THE INTERFERENCE

The first step toward eliminating interference is to identify and characterize it. Listening to the noise can reveal a lot. For example: if the noise heard varies with engine speed, its source must relate to the engine, such as the alternator, ignition system, or tachometer.

Because you are dealing with frequency-modulated equipment, determining if the noise is at receiver-sensitive frequencies is easy. With all squelch circuits open, simply apply an unmodulated signal to

the transceiver that is strong enough (10 mV at the Antenna Jack) to overcome any high frequency noise signal that could invade below. If noise remains, interference is at low frequencies that can enter only by proximity coupling to radio wiring or direct conduction.

Next, power the radio with an independent 12 V power source (such as another car battery). Isolate by moving wiring and/or the radio while listening for changes in the noise level. If the noise stopped when you connected the independent power source, noise voltages are conducting through on the positive circuit or the ground (see **ELIMINATING CONDUCTED NOISE**).

ELIMINATING CONDUCTED NOISE

If noise voltage is present on the power leads, there may be defective equipment in the vehicle electrical system that needs repair. An alternator with a bad diode has a large current ripple on its output, which produces a whine in the transceiver that varies in pitch with engine speed. Its current capacity is limited, but vehicle operation will not be noticeably impaired. Lights that dim during large current demands are a good sign of such a defect.

Another possible source of conducted interference is a fan motor in the same circuit to which the radio is connected. Because a fan also induces interference, confirm that noise is conducted into the radio (see **IDENTIFYING THE INTERFERENCE**). If the interference is conducted into the DC power leads of the radio, find a power connection point in the electrical system for the transceiver that is further from the fan circuit.

Noise voltages can also be added to the radio DC power input via the ground path. This is a condition where a high, noisy current shares the ground path of the radio equipment. For example:

Ground current of a fan motor finds its way to the vehicle battery through segments of metal body A-frame assemblies (see **Figure 4 - 8**). If the electrical bond between two parts is weak, and the radio ground current must also travel through this weak joint, a voltage drop induced across the joint by the fan current will appear at the radio power plug.

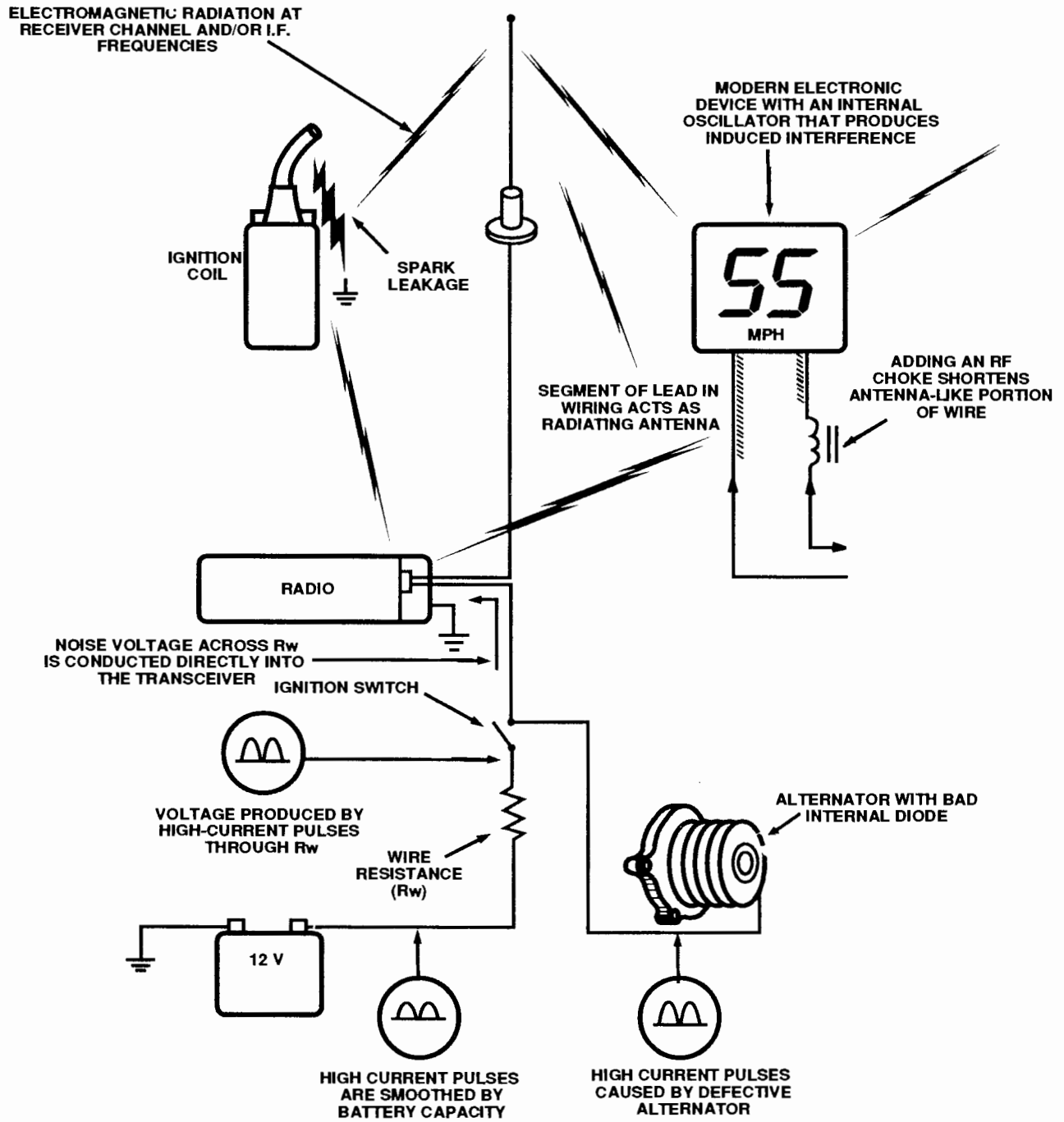
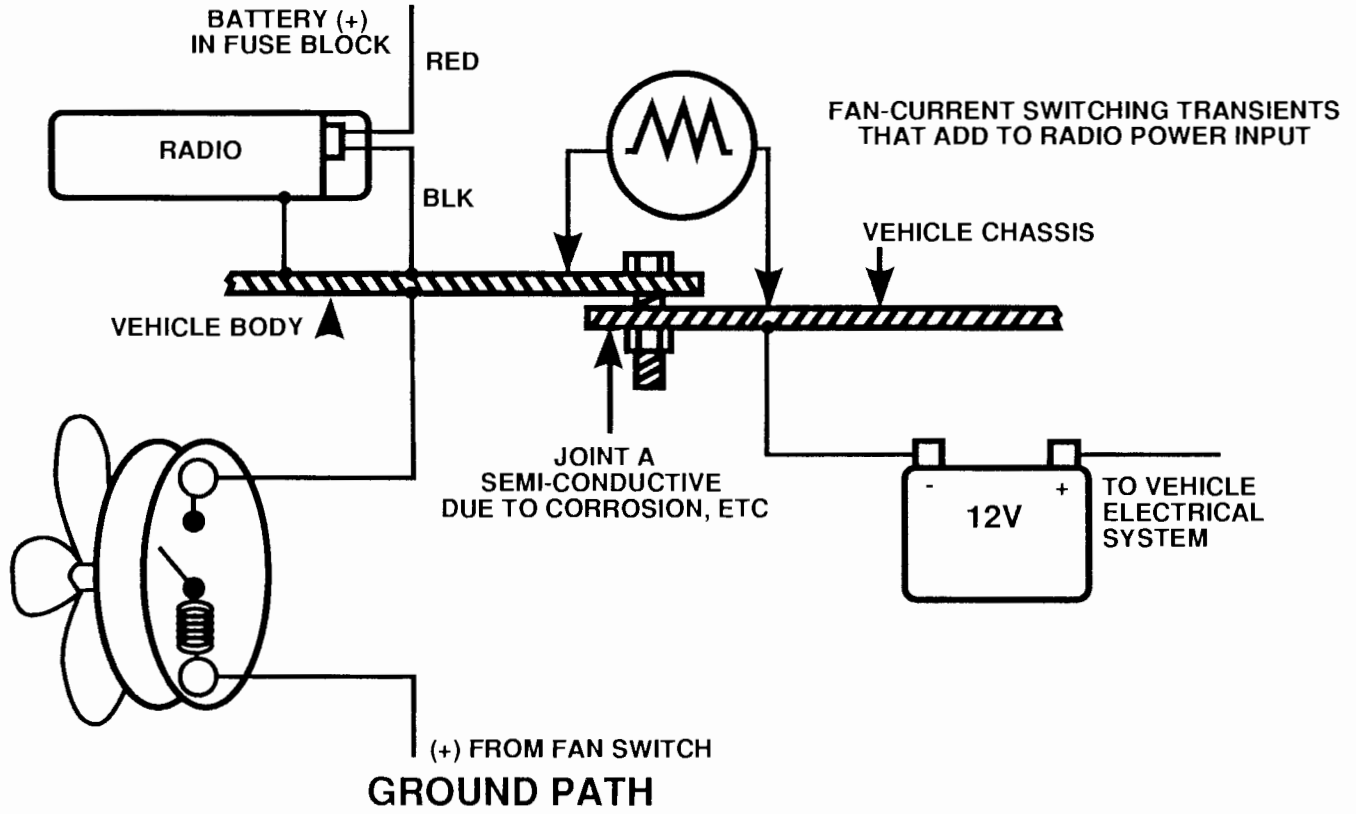
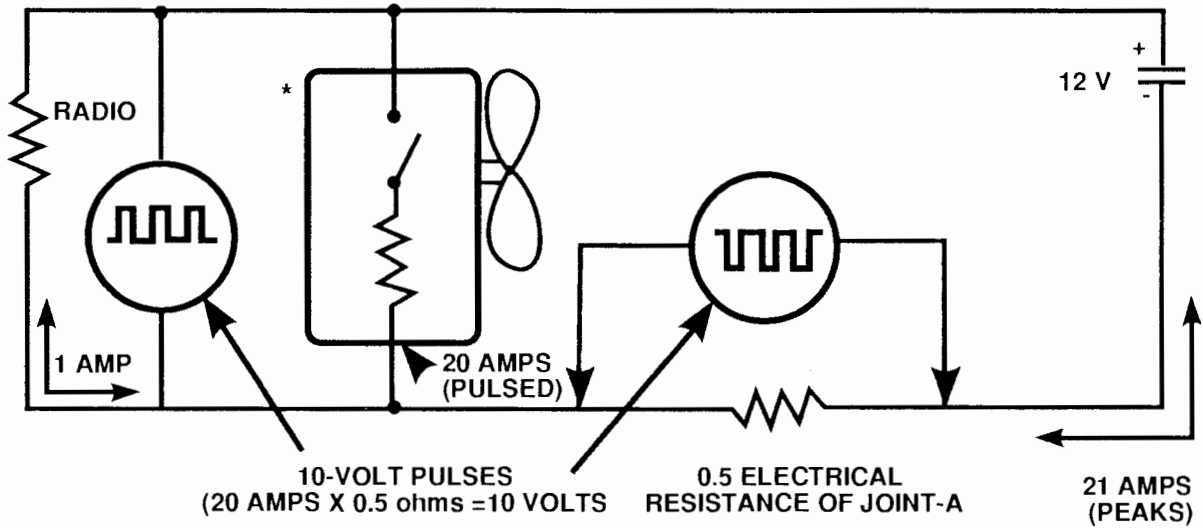

Figure 4 - 7 — Interference Paths



*THIS FAN MODEL EXCLUDES IT'S INDUCTANCE WHICH WOULD MAGNIFY THE ILLUSTRATED EFFECT



EQUIVALENT CIRCUIT

Figure 4 - 8 — A Noisy Ground

DC VOLTAGE CHARTS

Table 4 - 1 — Transistors

NAME	MODE	BASE	COLLECTOR	EMITTER
Q1	RX	0.7	0.0	0.0
	TX	0.0	5.0	0.0
Q2	RX	0.0-0.7	0.0-5.0	0.0
Q101	RX/TX	3.1	4.8	2.6
Q131	TX	0.9	8.6	0.7
Q201	RX	0.9	8.6	0.2
Q203	RX	0.8	7.6	0.6
Q243	RX	3.1	9.1	2.2
Q244	RX	2.4	4.3	1.7
Q301	RX/TX	—	—	0.0
Q406	RX	3.7	5.0	3.1
Q410	RX BUSY	4.9	5.0	4.2
	RX STANDBY	0.0	5.0	0.0
Q411	RX/TX	13.5	13.6	13.4
Q501	TX	0.6	5.4	0.0
Q502	TX	0.0	12.6	0.0
Q503	TX	—	12.6	0.0
Q504	TX	12.5	5.4	13.6
Q701	RX/TX	9.0	9.1	8.2
Q704	RX	8.8	0.0	8.8
	TX	8.1	8.4	8.8
Q705	RX	4.7	0.0	0.0
	TX	0.0	7.9	0.0
Q712	RX	1.6	7.0	0.9
Q732	TX	1.0	7.6	0.4
Q733	RX/TX	1.8	8.0	1.3
Q734	TX	1.8	8.2	1.3
Q774	RX/TX	9.0	—	9.0
Q775	RX/TX	9.0	9.0	9.0
Q776	RX/TX	0.0	0.0	0.0
Q778	RX/TX	4.6	0.0	0.0
Q901	RX/TX	5.5	8.4	4.8

Table 4 - 2 — Transistor Packs

NAME	MODE	PIN NO.					
		1	2	3	4	5	6
Q302	RX	—	—	0.0	—	—	0.0
Q401	RX BUSY	4.8	0.0	0.0	0.7	0.0	0.0
	RX STANDBY	0.0	0.7	7.6	0.0	0.0	0.0
	TX	0.7	—	—	—	0.0	0.0
Q403	RX	—	—	12.7	0.0	0.0	—
	TX	—	—	11.6	2.0	1.4	—
Q702	RX	7.1	7.2	7.8	0.0	0.0	7.8
	TX	0.0	0.7	8.0	7.8	7.2	8.0
Q703	RX	0.0	0.0	0.0	8.6	4.6	0.0
	TX	2.9	2.9	0.0	0.0	0.2	0.0
Q771	RX/TX	3.8	4.4	4.7	0.0	0.0	0.0
Q778	RX	0.0	2.2	0.0	0.0	0.0	0.0
	TX	2.0	2.2	0.0	0.0	0.0	0.0

Table 4 - 3 — FET's

NAME	MODE	GATE 1	GATE 2	DRAIN	SOURCE
Q241	RX	0.0	—	9.0	2.2
Q242	RX	0.0	—	9.0	0.52
Q408	SQ OPEN <i>CF</i>	4.7	—	5.0	5.0
	SQ CLOSED <i>CF</i>	0.0	—	5.0	5.0
Q711	RX	3.4	4.7	7.8	3.0
Q731	TX	3.4	4.7	7.8	3.0

Table 4 - 4 — Integrated Circuits, 8 Pins or Less

NAME	MODE	PIN NO.							
		1	2	3	4	5	6	7	8
IC401	RX/TX	13.5	0.0	9.1	—	—	—	—	—
IC402	RX/TX	13.5	0.0	5.0	—	—	—	—	—
IC405	RX/TX	0.9	2.8	2.8	0.0	4.1	4.1	3.3	9.0
IC406	RX	6.5	6.5	6.4	0.0	6.0	13.5	6.5	—
IC407	RX/TX	—	—	—	0.0	4.4	4.4	4.4	9.0
IC902	RX/TX	4.9	4.9	0.0	—	—	—	—	—
IC903	RX/TX	0.0	0.0	0.0	8.2	—	1.2	9.1	3.6

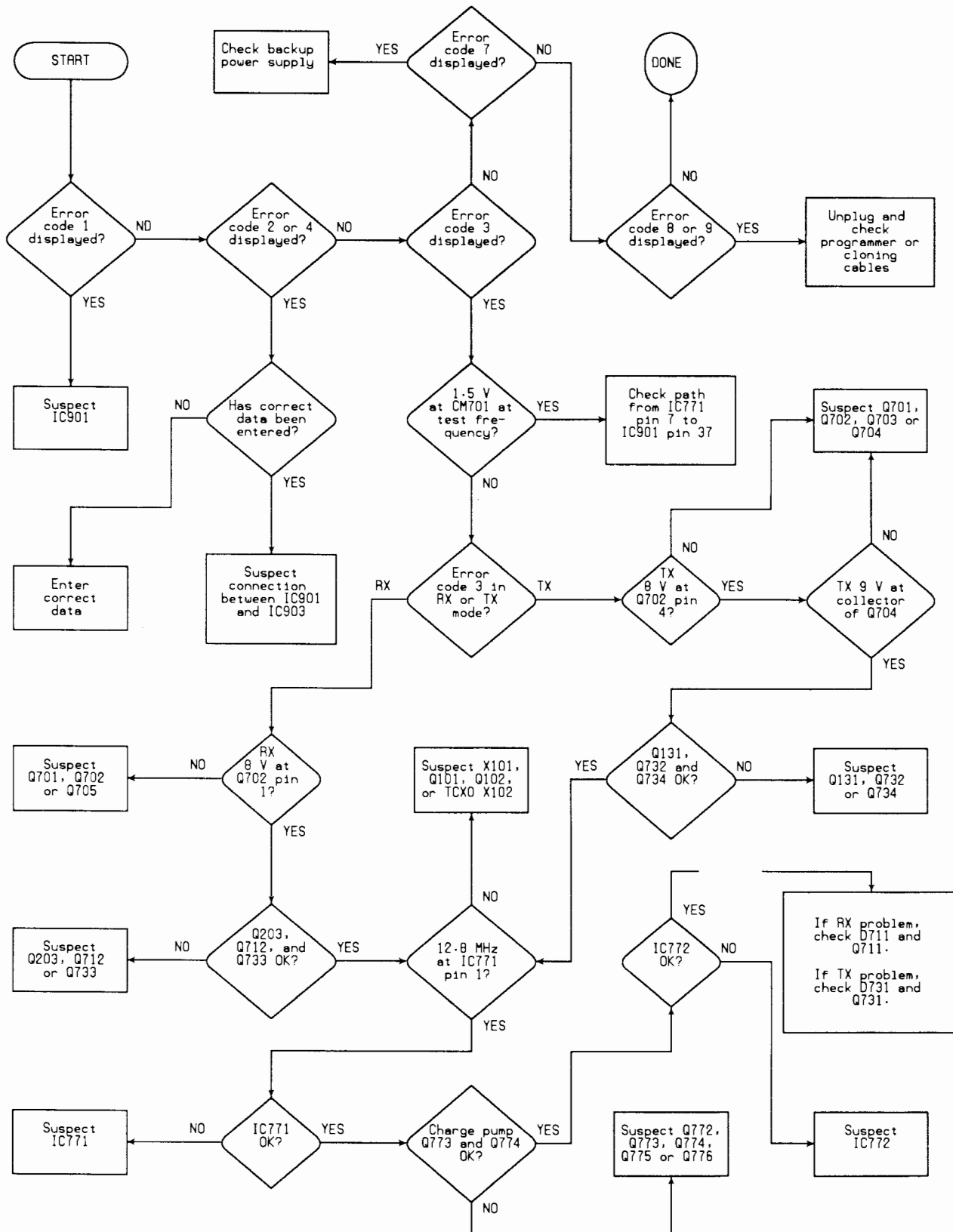

4

Troubleshooting Chart 4 - 2 — Error Code Displayed

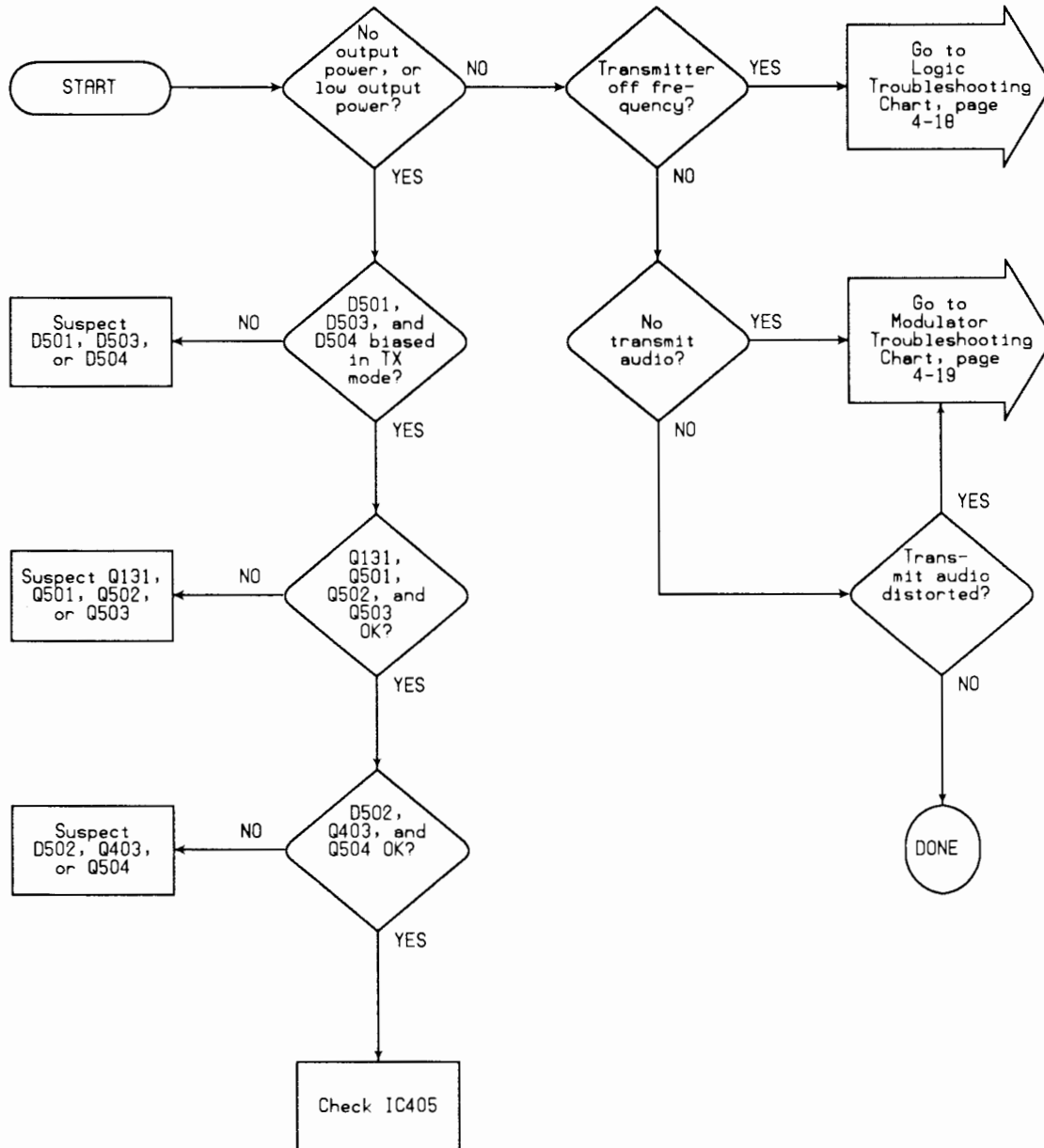

Troubleshooting Chart 4 - 3 — Transmitter Problem

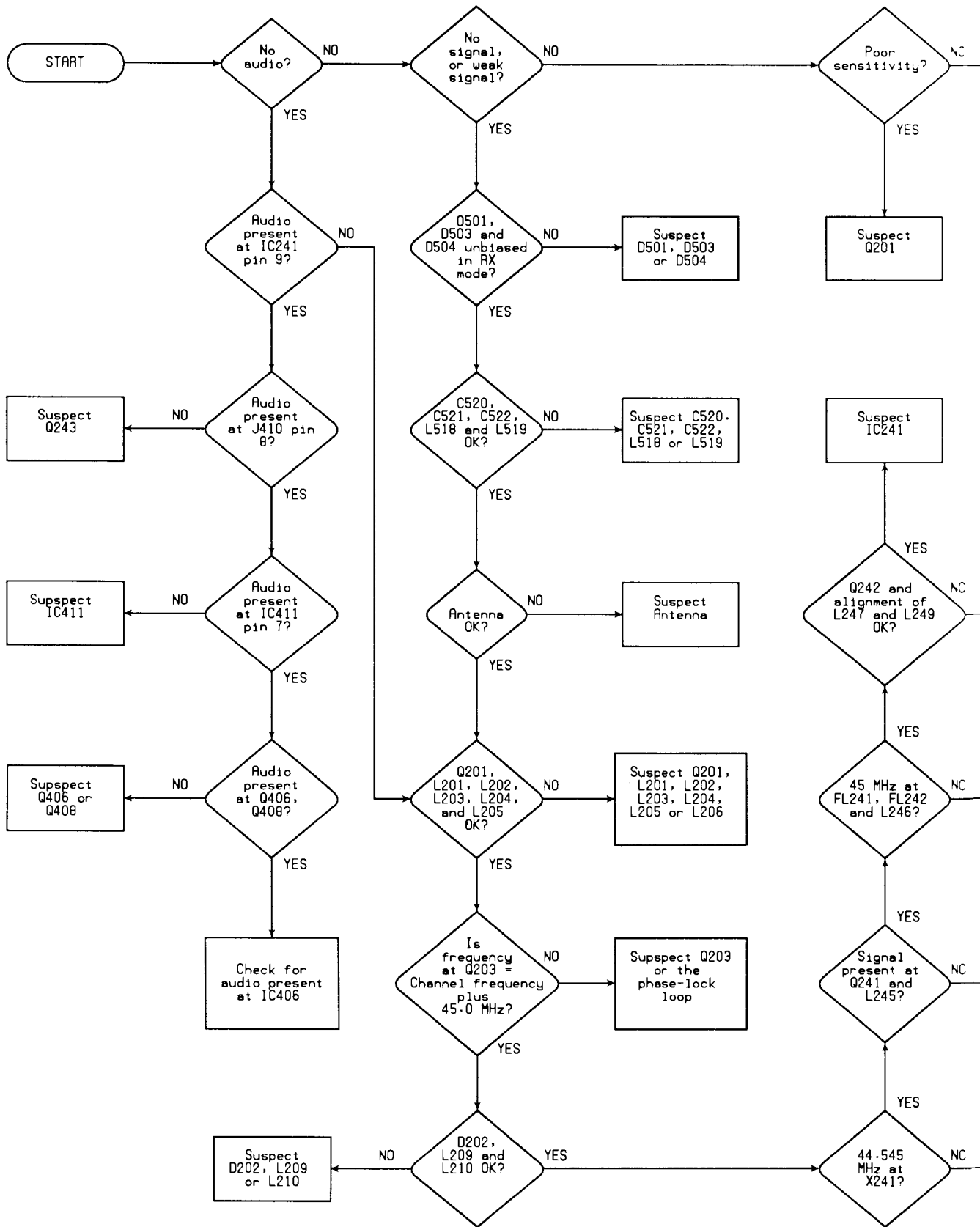

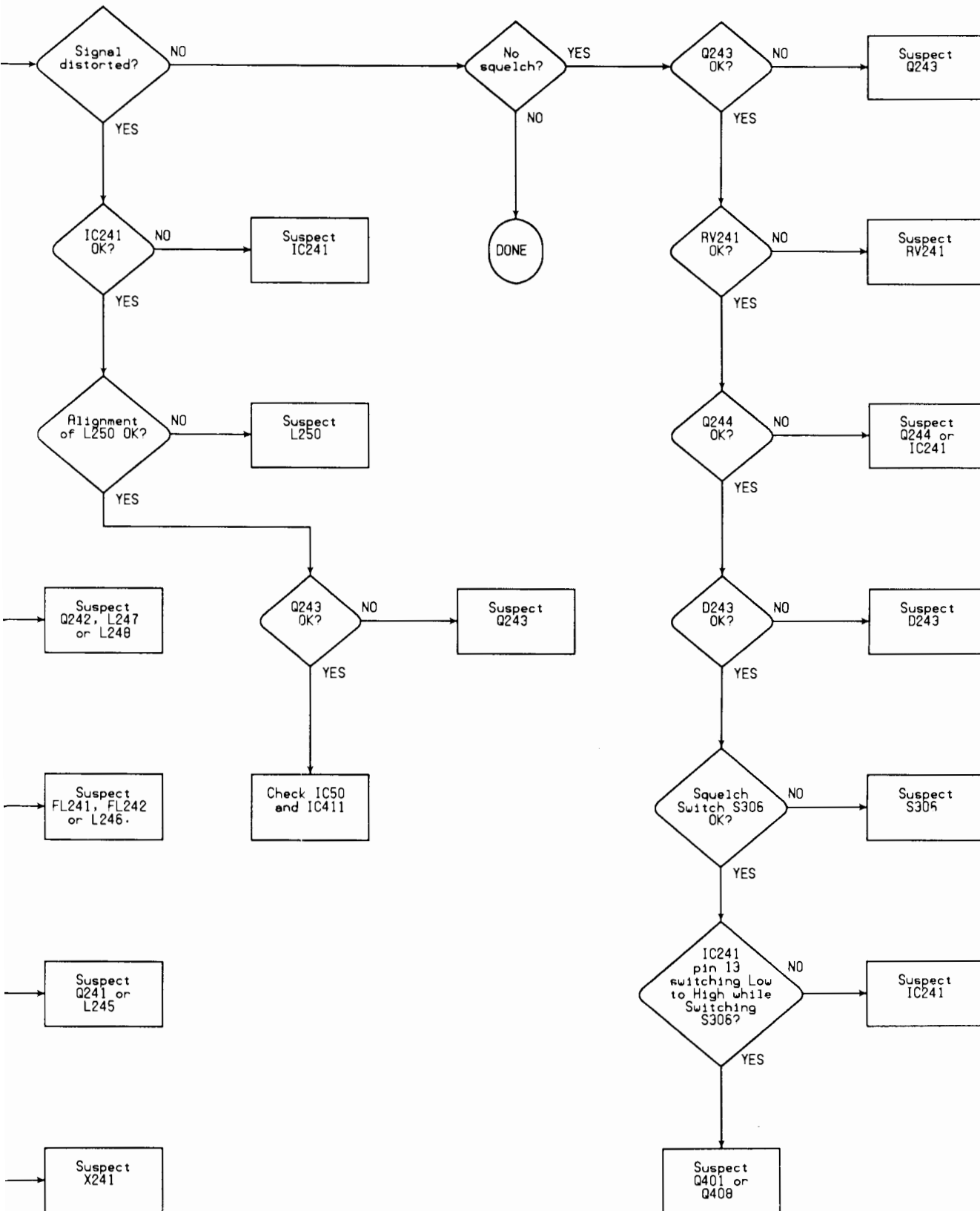

Troubleshooting Chart 4 - 4 — Receiver Problem

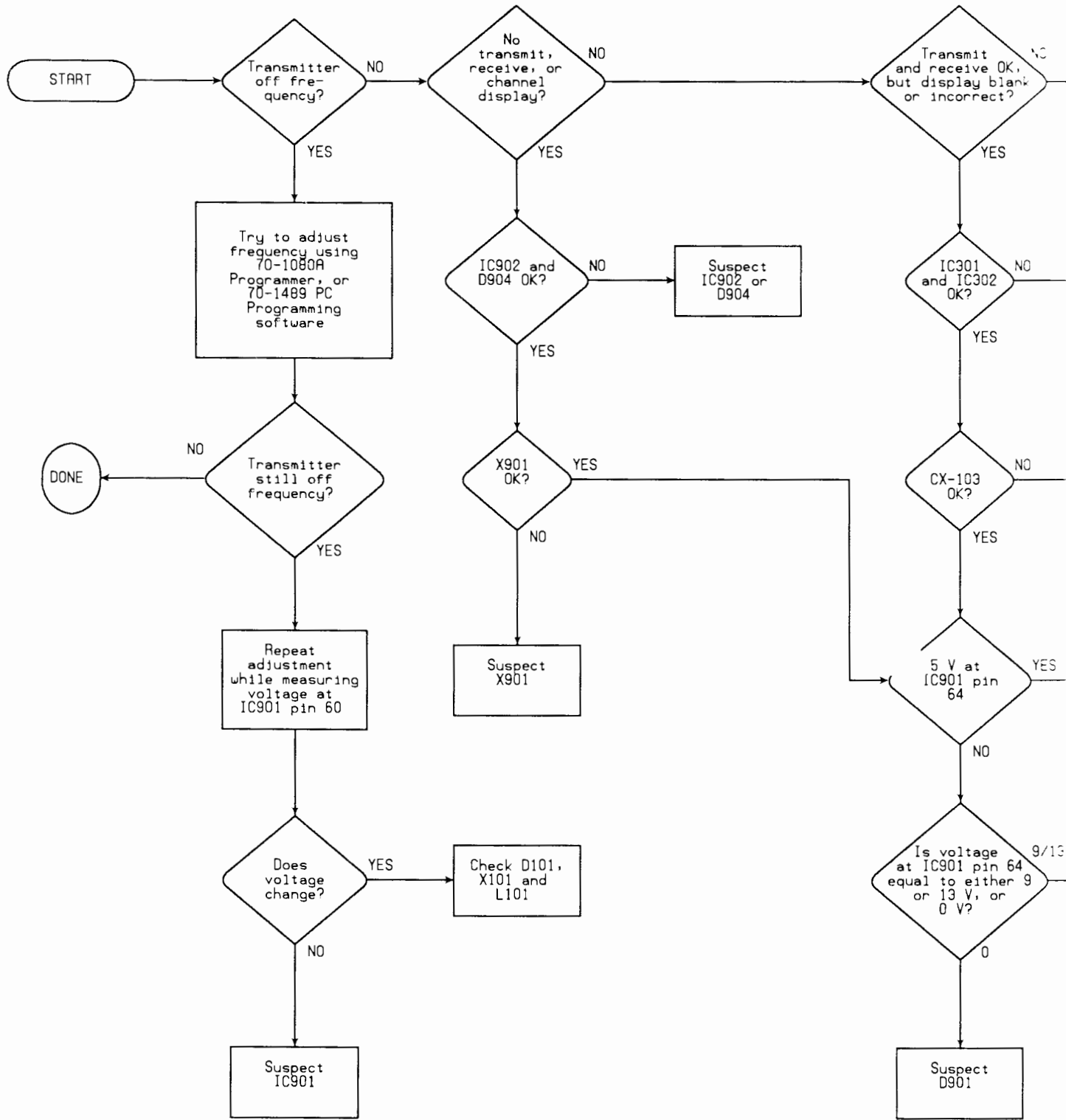

Troubleshooting Chart 4 - 5 — Logic Problem

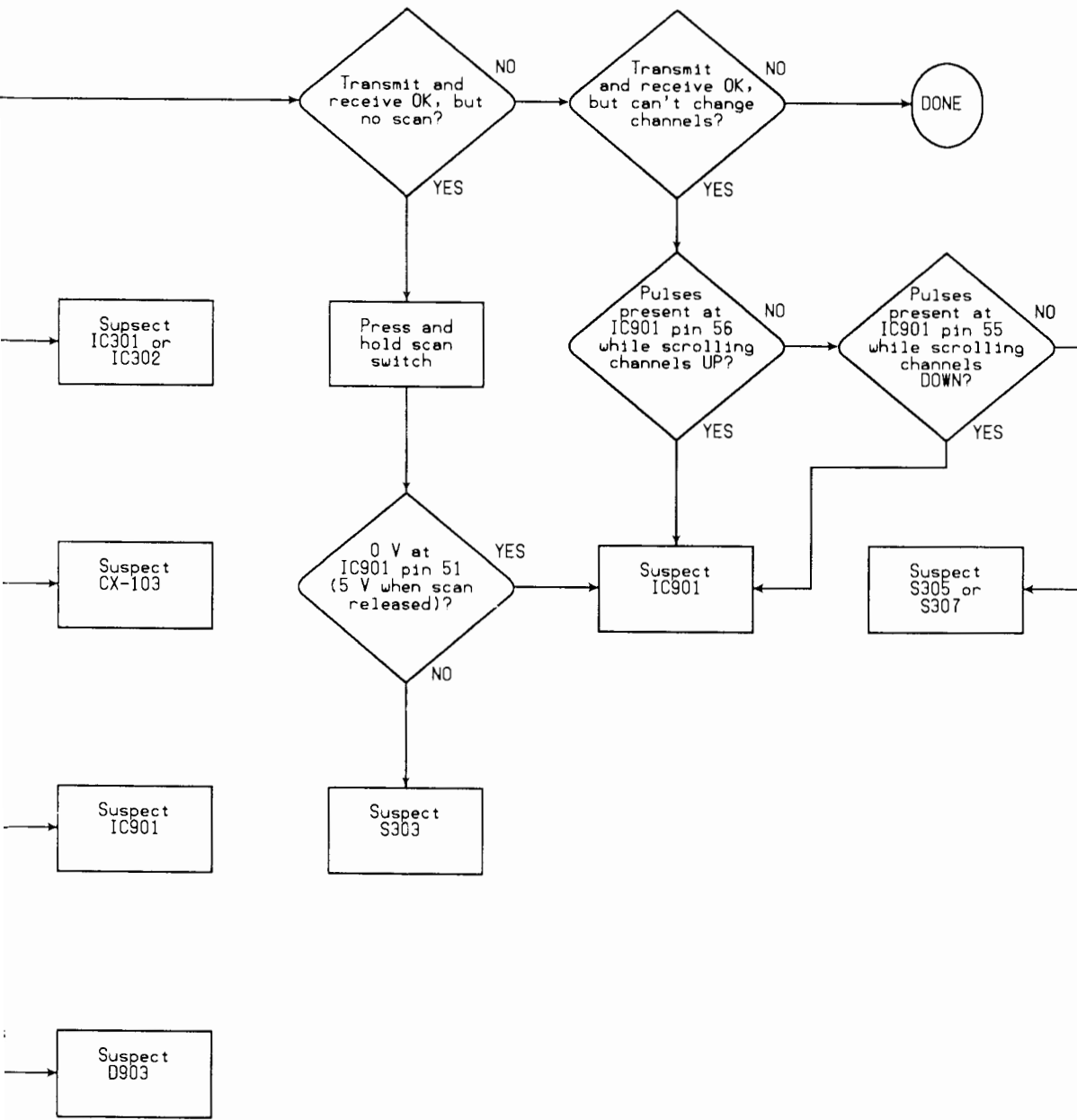

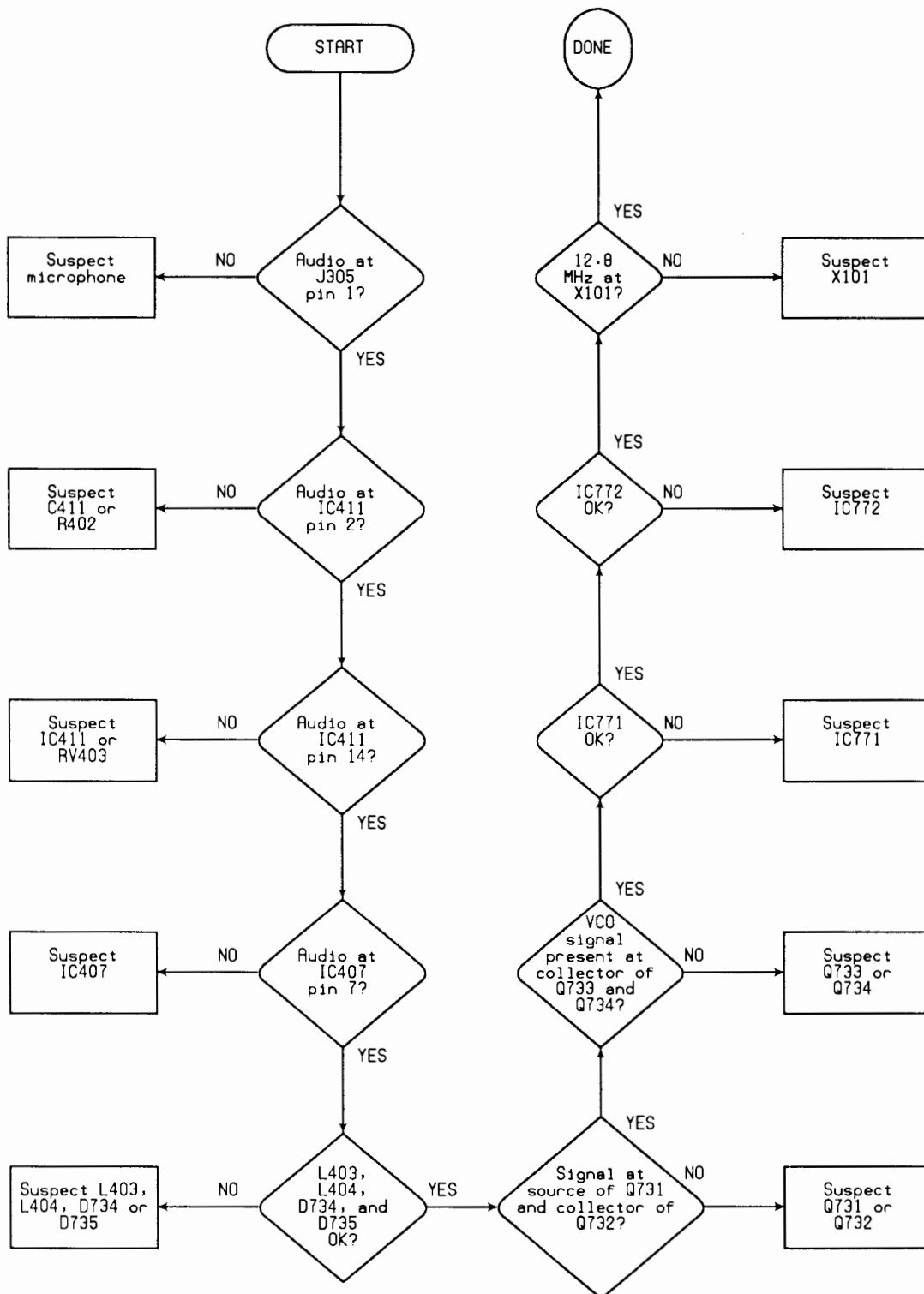

4

Troubleshooting Chart 4 - 6 — Modulator Problem

SECTION 5

CIRCUIT DESCRIPTIONS

The 70-1336 unit is made up of three major sections: the RF section, the PA section, and the Logic Section.

RF SECTION

The RF Section consists of a frequency synthesizer, a transmit modulator, a receiver, and receive audio amplifier circuits.

SYNTHESIZER

Radio frequency signals for transmission and receiver injection are produced by voltage-controlled oscillators (VCO's) in a Phase-Lock Loop (PLL) configuration.

• Voltage Controlled Oscillators

In this radio, two VCO's are used — Q731 operates in transmit mode to generate transmit frequencies; Q711 operates in receive mode to generate receive injection frequencies. Each is buffered independently; by Q732 and Q712 respectively. Output of the buffers are amplified by Q131 and Q203 respectively. RF signal at receiver injection frequency ($F_c + 45.0$ MHz) is applied from the LO amplifier Q203 in the receiver circuit. RF signal from Q131 is amplified further by the PA portion.

When the frequency of the VCO output drifts away from the desired value, the loop adjusts the steering voltage to compensate.

A single VCO tank can tune across the entire 24 MHz channel spread. Only one of the two tanks is switched in at a time and they are selected by TXDL from the Logic portion. The microcomputer sets TXDL to logic low during transmit mode.

Resonance of each VCO tank is voltage-tuned by varactor diodes D711 and D731 respectively. Loop steering voltage applies reverse bias to all these varactor diodes simultaneously. As steering voltage increases, varactor diode capacitance decreases, so that net capacitance in each tank decreases. This increases resonant frequency of the tanks.

• Loop Dividers

The amplitude of the VCO signal from Q733 collector for TX and Q734 collector for RX is sufficient to

feed prescaling frequency divider, IC771, which applies an output pulse once every 64 or 65 input cycles. Additional frequency division is also performed within IC771 to produce 2.5 kHz. X101 is a temperature-compensated crystal oscillator that produces a reference frequency of exactly 12.8 MHz. The reference frequency is divided by IC771 to produce 2.5 kHz, which is compared to the down-counted 2.5 kHz sample of VCO output. Normally the loop response is slowed enough by the active filter to block 5.0 kHz reference noise and prevent loop correction of voice modulation during transmit. Higher active filter rolloff frequency is selected by the microcomputer system on the Logic Board when the radio changes channels or it is keyed and unkeyed, by a logic low applied to the base of Q772. This increase in loop response speeds locking time.

A connection from an intermediate point in the phase/frequency comparator in IC771 is made at pin 7. When the loop is out of lock, the down-counted VCO sample is not in phase with the 2.5 kHz reference and low going pulses appear here, which produce a logic low at pin 7. This logic low is applied to Q778 and Q771 to switch to Q403-1/2 and Q504. Q504 then clamps off bias to transmit PA preamplifier Q501 to prevent emission of erratic signals generated by the uncontrolled VCO.

• Modulator

Voice signals from the hand-microphone are applied to audio filter IC411, where frequency response is pre-emphasized and splatter filtered. Gain is such that stronger signals bring IC411 into clipping, which limits modulation. Harmonics above the 3 kHz modulation pass-band are removed by the 2.5 kHz pi-network in IC411. Modulation signals are then adjusted by RV403 so that modulation at limiting at IC407 will produce transmitted carrier deviation of ± 5 kHz. Output of processed voice signals at IC411 pin 14 is fed to the gain control IC407.

RECEIVER

• Preselector

Through PIN-diode gates in the PA, RF signals are routed to the receiver input. Signals at image frequencies and frequencies far removed from the desired channel are rejected by a preselector comprised of six top-coupled, parallel tanks: L201, L202, L203, L204, L205, and L206. No tuning of these tanks is required for the entire 24 MHz channel frequency spread. Q201 provides adequate gain to overcome preselector signal losses and maximize receiver sensitivity.

• Injection

First Local Oscillator signal (channel frequency plus 45.0 MHz) is synthesized by the phase-lock loop and applied to Q203. A low pass filter is provided at the output of Q203; this rejects extraneous synthesized signals. No alignment for the first local oscillator signal is required.

• First Mixer

To maximize intermodulation immunity, a balanced configuration is used for the first mixer stage. High Injection is applied to L210-primary and preselector output is applied to its secondary center tap. A diode double balanced mixer using quad-diode D202 is employed. High injection is applied to the push-pull input of the mixer. Some of this signal appears at mixer output, but most is lost because L209 is designed to operate at the 45 MHz first IF frequency.

• First IF

Mixer output is applied to Q241, which drives L244. L244 tunes to match the input impedance of 45 MHz monolithic crystal filter FL241. L246 matches the output of FL241 to the input of FL242. FL241 and FL242 reject signals outside the channel bandwidth. L247 matches the output of FL242 to the input of Q242. Q242 amplifies the first IF signal at least 20 dB, and it is coupled to second IF IC241 by L248.

IC241 contains all second IF circuitry, a quadrature demodulator, and a threshold gate. X241 and circuitry in IC241 generate second LO injection

44.545 MHz. A double-balanced mixer, that cancels both input signals is used so that additional tuned circuits at its output are not needed. Mixer output signal of 455 kHz (IC241 pin 3) is bandpass filtered further by FL243 and FL244 then super-amplified (100+ dB) by the second IF amplifier/limiter within IC241 (pin 5).

• Demodulation

The quadrature detector in IC241 is another double-balanced mixer to which limiter output is applied. Its second input is taken from 455 kHz tank L250, which is also fed with limiter output (IC241 pin 7). Frequency deviation from carrier center will cause phase difference between the two demodulator input, which produces output. Preamplified recovered audio appears at demodulator output, pin 9. C264, C265, and L251 attenuate signals above 100 kHz.

• Audio

Recovered audio from IC241 is routed to op amp IC411, and applied to volume control RV301. Output of the RV301 is applied to the squelch gate Q408, then to audio amp IC406. Power Amplifier IC406 amplifies the audio signal and drives the speaker.

• Squelch

Audio signals at lowpass filter L251 are routed through Squelch Range RV241, which calibrates squelch-break level when the side panel squelch switch is on. Signals at RV241 top feed a two-tank 60 kHz filter. The resulting 60 kHz signal is amplified by IC241 and Q244, then rectified by D243 to produce a DC voltage that varies inversely with received RF-carrier level. When the squelch switch is in the off position, it sinks all current from D243 so that squelch is open. When the squelch switch is in the on position, RV241 and a temperature-compensated circuit made up of R271, R272, and R273 limits the current from D243 to set a squelch threshold of $0.2\mu\text{V}$. The DC voltage is input to a level detector within IC241 and detector output is an open collector that sinks voltages to logic low when on-channel receiver input is above the squelch threshold established by RV241. Level detector output is applied through NSQ, the interconnect to microcomputer input port pin 58, so that the microcomputer can take appropriate action.

30-WATT PA SECTION

RF POWER AMPLIFIER

A PC-board stripline is used to match the base of Q501 to the coax. RF impedance at the collector of Q501 is transformed by PC-board stripline to the base terminal of driver Q502 and the collector of Q502 is transformed to the base of Q503. RF impedance at the collector of final-stage Q502 is again transformed by PC stripline and fine-tuned by CV501 match circuit impedance at RF-gate D501. L514—L517 and C515—C519 comprise the harmonic filter. R512 and R513 serve to drain static and other DC potentials from the antenna.

ANTENNA GATE

In receive mode, PIN diodes D501, D503 and D504 are unbiased. The RF signal path from the final amplifier Q503 is severed, and the impedance matching network consisting of L518, C520, C521, L509, and L522 routes signals from the antenna to the receiver input through 50 Ω coax at J501.

D501, D503 and D504 are biased on in transmit mode. The receiver port network (L518 etc.) is

detuned so that it appears as a high impedance to the antenna, and D501 couples final amplifier output to the antenna at J501.

AUTOMATIC POWER CONTROL

A PC stripline ahead of the harmonic filter, and a thin PC runner adjacent to it, serves as a directional coupler. D502 rectifies a small RF sample that is developed across the thin runner, producing a DC voltage that increases with RF power traveling forward into the antenna. This power level sensing voltage is applied to the inverting input of the comparator IC405 pin 6. The reference voltage applied to the comparator IC405 pin 5 is fed from RV402.

Output of the comparator IC405 is applied to Q504 via Q403, which is a current source that feeds primary DC to the collector circuits of predriver Q501.

The feedback loop, from the directional coupler to Q504 via the comparator input IC405 pin 6 holds RF output power at the constant level determined by the reference voltage of IC405 pin 5, which is initially adjusted using RV402.

LOGIC SECTION

MICROCOMPUTER

Radio operation is under control of a microcomputer system located on the Logic Board. This system is comprised of Microcomputer IC901 and 2K EEPROM IC903.

All CPU activity is performed step-by-step in time with a clock. The frequency of the clock is fixed by crystal X901. Because of the high clock speed, microcomputer activity seems instantaneous.

• Display and Switches

Pressing S305 (UP) or S307 (DN) applies a logic low to pin 56 or 55 of IC901, respectively. IC901 interprets this request as a channel change up or down and outputs the appropriate BCD display data from pin 13—pin 16 (DSP3—DSP0), which is applied to the BCD-to-Seven Segment Display driver, IC301. The channel display data is latched into IC301 by

the DSP STB from pin 12 of IC901 via Q301. Once latched, the appropriate channel is displayed on the channel display, D3C2.

Pressing S301 (MON) applies a logic low to pin 50 of IC901. IC901 responds by putting CTCSS/DCS decode in the monitor state and outputs a logic high from pin 13 (DSP3) which is latched in IC302 by the LED STB sent from pin 11. The logic high is inverted by Q302-2/2 to light the MON LED, D304.

Pressing optional switch S303 (PSCAN) applies a logic low to pin 51 of IC901. IC901 places the radio in the scan mode and indicates this by outputting a logic high from pin 16 (DSP0) which is latched into IC302 by the LED STB sent from pin 11. The logic high is inverted by Q302-1/2 to light the optional PSCAN LED, D305.

CIRCUIT DESCRIPTIONS

70-1336

During transmit, TX 9V is present at the anode of D701, which applies a positive voltage to the anode of the TX LED, turning it on.

When a signal is received, Q410 is turned on, which allows a positive voltage to be applied to the anode of the BUSY LED via D401-3/3

• CTCSS/DCS Encode/Decode

IC901 controls CTCSS/DCS encode and decode. In receive mode, the receive audio signal is high-pass filtered at IC50 to remove the CTCSS/DCS tones/codes. The CTCSS/DCS square wave is input through the Signal I/O line, pin 8 of IC901. IC901 determines if the CTCSS/DCS signal received is a valid tone/code. If it is valid, the output at pin 21 (MUTE) will go to logic high, which opens radio squelch.

In TX mode, pin 8 of IC901 will output the programmed CTCSS/DCS tone/code. TXDL goes low, turning off Q1, which turns on IC2-2/4 and IC2-4/4, allowing the tone/code on the Signal I/O line to pass through IC1. IC1 is a programmable filter that "cleans up" CTCSS/DCS tones/codes. The generated tone is applied to Level Adjust RV1, and from there to Balance Control RV401 via C6. The signal is then sent to IC411-3/4, where it is mixed with the mic audio, and also to D102 in the reference oscillator.

• RX and TX Switching

In receive mode, TXDL (pin 33 of IC901) is at logic high. This turns Q705 on, which causes Q702-1/2 to turn on. This applies RX8V to the VCO. Also, when TXDL is high, Q703-1/2 turns on, and Q703-2/2 turns off. This turns Q702-2/2 and Q704 off, which turns TX8V and TX9V off.

In transmit mode, TXDL is at logic low. This turns Q703-1/2 off, which turns Q703-2/2 on. This turns Q702-2/2 and Q704 on, which turn TX8V and TX9V on. Also, when TXDL is low, this turns Q705 off, which causes Q702-1/2 to turn off. This turns RX8V off, and TX8V and TX9V on.

• Data Control

When the radio is turned on, the contents of EEPROM IC903 are serially clocked into IC901 so that it can set up receiver frequency, scan operation, transmit/receive hold timer, busy-channel lock-out timer, time-out-timer and reference oscillator frequency control.

When a channel is changed, or when PTT is pressed, the contents of EEPROM IC903 are sent to IC901. IC901 then uses this data to send the appropriate information for the channel selected to IC771, CTCSS/DCS circuitry, display circuitry, and any signalling options.

• Reference Oscillator Frequency Control

The resistance of thermistor R107 varies with temperature. This resistance change is converted to a voltage by IC405. Output of IC405 is sent to IC901 pin 59 (TEMP). IC901 compares this data internally with the preset crystal type and programmed offset, and outputs a compensating voltage from pin 60 (F CONT). This voltage is sent to varactor diode D101 to stabilize the frequency of the reference oscillator.

DC POWER AND RESET

5 V DC power to all logic circuitry in the Logic portion is supplied from switched 13.6 V and is regulated by IC402. Microcomputer IC901 is powered by the 5 V drop across D903, which is sourced by IC401 9 V regulator supply.

Table 5-1—IC901 PINOUTS

Pin No.	Pin Name	I/O Flow	Function Label	Logic & Function
1	P37	I	PC RTS	Programmer Interface
2	P36	O	PC CTS	Programmer Interface
3	P35	O	PC RD	Programmer Interface
4	P34	I	PC SD	Programmer Interface
5	P33	I	PC CD	Programmer Interface
6	P32	O	BEEP	Beep Tone Output
7	P31	O	CLK	Clock Output for CTCSS/CDCSS
8	P30	I/O	SIGNAL IO	Signal I/O for CTCSS/CDCSS
9	P57	O	LEDCHK	LED Check Output
10	P56	O	LEDAUX	not used
11	P55	O	LED STB	Paralled-Data Strobe for Indicators
12	P54	O	DSP STB	Parallel Data Strobe for Displays
13	P53	O	DSP3	Display/LED Data
14	P52	O	DSP2	Display/LED Data
15	P51	O	DSP1	Display/LED Data
16	P50	O	DSP0	Display/LED Data
17	P67	O	AUXOUT	Aux Switch Output (Low = ON)
18	P66	I	TASW	Talk-around Switch Input (Low = ON)
19	P65	O	SCRB STB	Serial Data Strobe for Voice Scrambler
20	P64	O	AUX STB	Serial Data Strobe for AUX
21	P63	O	MUTE	Low = MUTE
22	P62	I	HANGUP	Low = HANG UP
23	P61	I	PTT	Low = TX
24	P60	I	VLINT	Low = LOW VOLTAGE
25	R/W	O	---	not used
26	SYNC.	O	---	not used
27	CNV _{SS}	I	---	GND
28	RESET	I	---	Low = MICROCOMPUTER RESET
29	X _{IN}	I	---	Crystal Oscillator, 8 MHZ
30	X _{OUT}	O	---	Crystal Oscillator, 8 MHZ
31	0	O	---	not used
32	V _{SS}	I	---	GND
33	P27	O	TXDL	Low = TX ACTIVATE
34	P26	O	DA STB	Serial Data Strobe for D/A Converter
35	P25	O	VCOCHG	VCO Switch Signal Output
36	P24	O	LPSW	Loop Switch Signal Output
37	P23	I/O	PLCL	Synth Unlock (Low = UNLOCK)
38	P22	O	DSTB	Serial Data Strobe for Synthesizer
39	P21	O	DCLK	Clock for Serial Data
40	P20	O	DATA	Serial Data Output
41	P17	I/O	---	not used
42	P16	I/O	---	not used
43	P15	I/O	---	not used
44	P14	I/O	---	not used
45	P13	I/O	CS1	Chip Select for EEPROM
46	P12	O	SK	Clock for EEPROM
47	P11	O	DI	Data Input into EEPROM
48	P10	I	DO	Data Output from EEPROM
49	P07	I	AUXSW/CH0	AUX Switch (Low = ACTIVE)/CHNL NO. INPUT
50	P06	I	MONSW/CH1	Monitor Switch (Low = ACTIVE)/CHNL NO. INPUT
51	P05	I	P.SCAN/CH2	PRI Switch (Low = ACTIVE)/CHNL NO. INPUT
52	P04	I	SCNSW/CH3	SCAN Switch (Low = ACTIVE)/CHNL NO. INPUT
53	P03	I	DEPWRSW/CH4	DE-POWER Switch (Low = ACTIVE)/CHNL =NO. INPUT
54	P02	I	---/CH5	not used/CHNL NO. INPUT
55	P01	I	DNSW/CH6	DOWN Switch (Low = ACTIVE)/CHNL NO. INPUT
56	P00	I	UPSW/CH7	UP Switch (Low = ACTIVE)/CHNL NO. INPUT
57	P42	I	VL _{TIN}	not used
58	P41	I	NSQ _{IN}	NSQ Status Input (High = RECEIVE)
59	P40	I	TEMP	Thermal Sensor Input
60	DA2	O	F CONT	Reference Frequency Control Output
61	DA1	O	---	not used
62	VREF	I	---	Reference Voltage Input to Convert A/D
63	AVSS	I	---	GND
64	VCC	I	---	+5 V

5

SECTION 6

DIAGRAMS

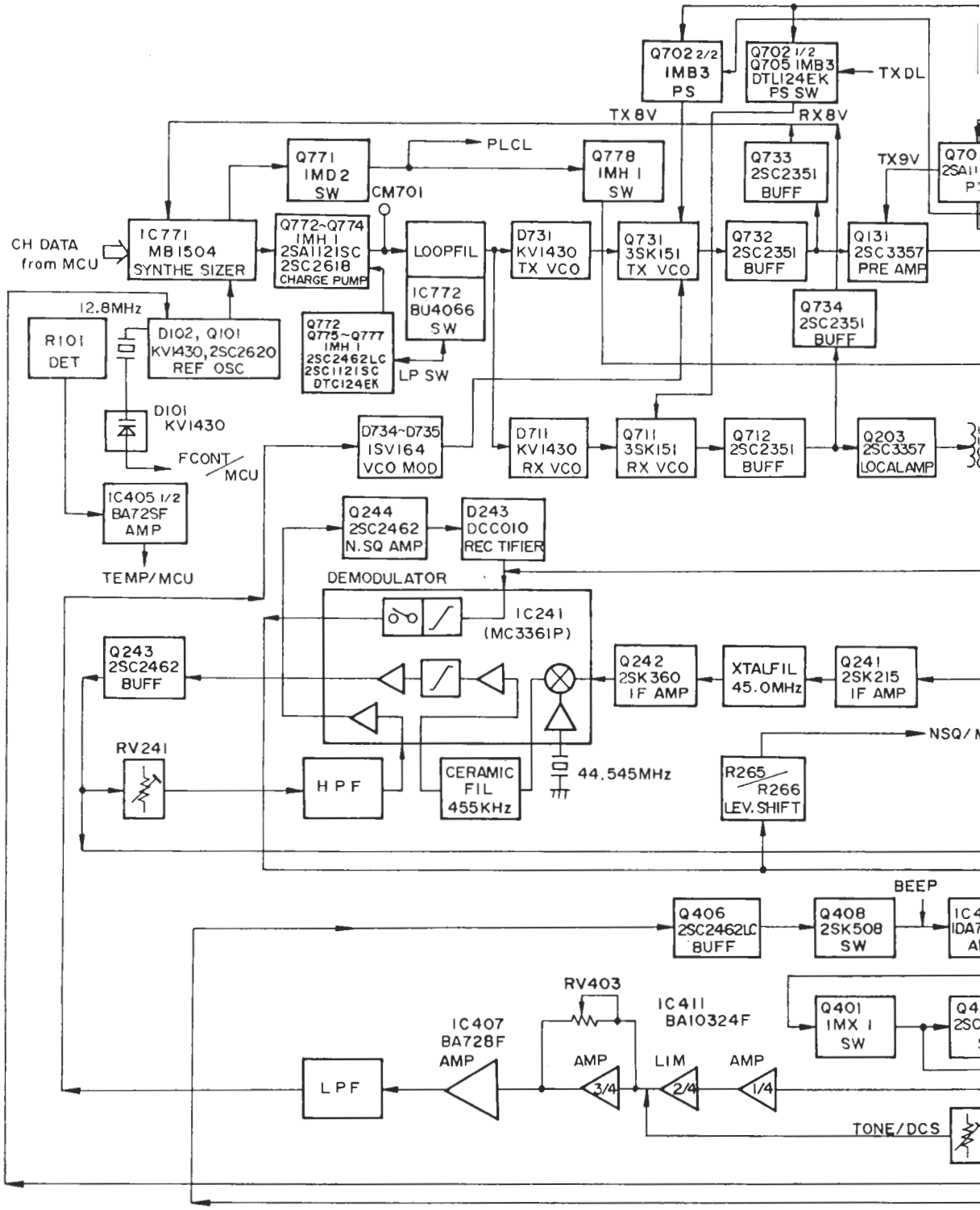

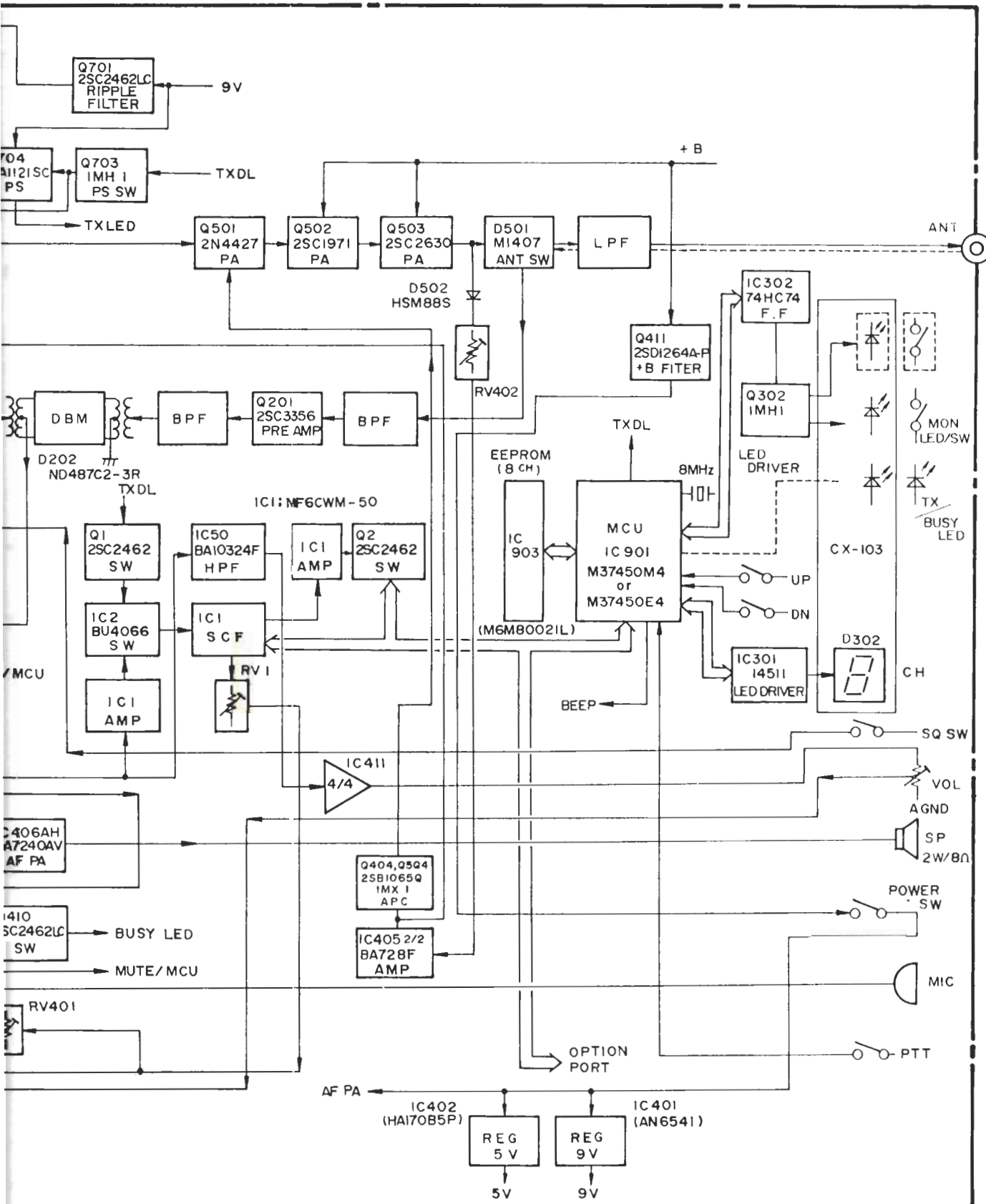

OPTION

WIRING DIAGRAM

70-1336

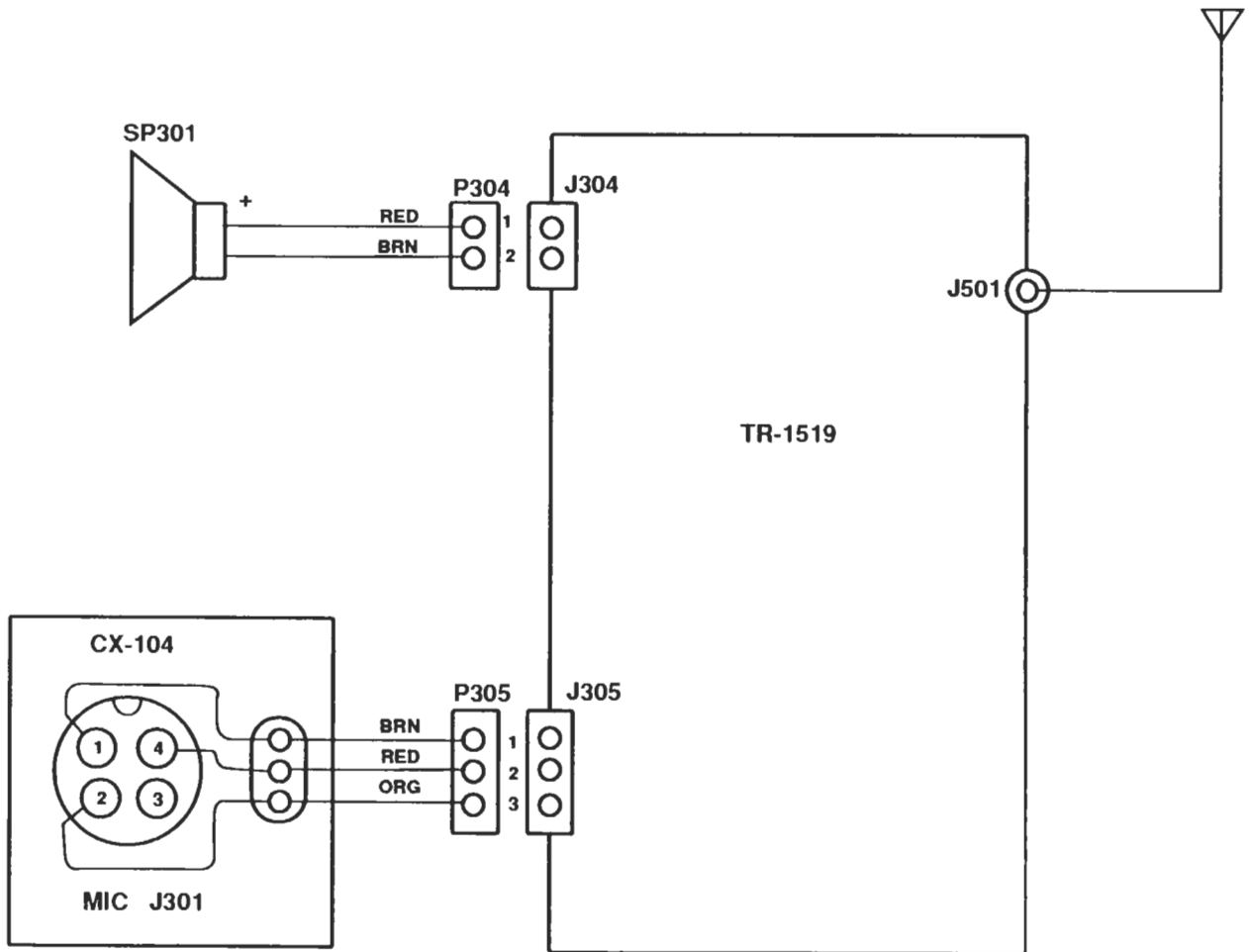

CX-103 LAYOUT

TOP VIEW

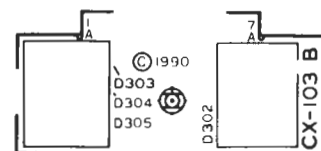
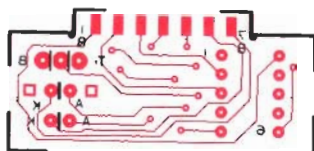
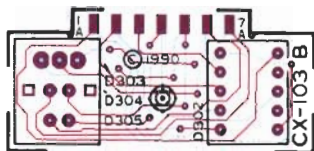

BOTTOM VIEW

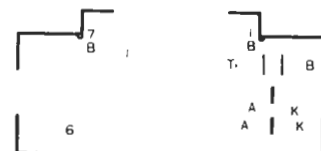
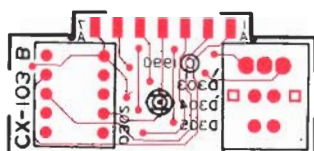
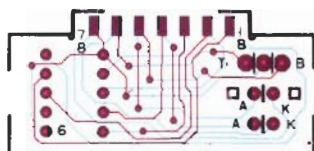

CX-104 LAYOUT

TOP VIEW

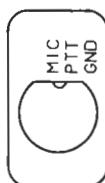
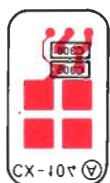

BOTTOM VIEW

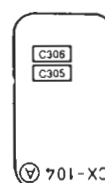
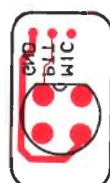
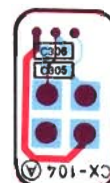

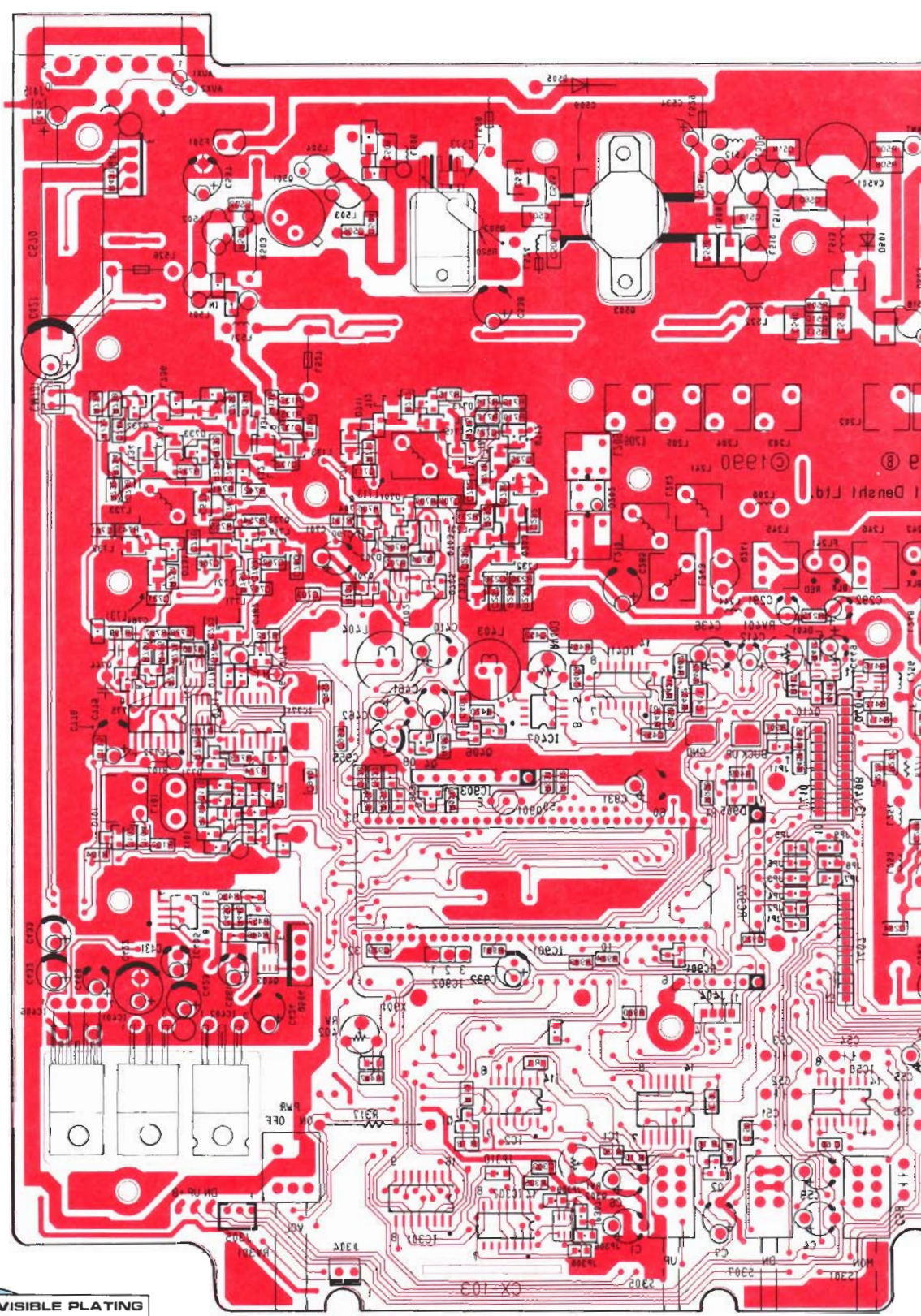

BLUE VISIBLE PLATING

RED UNDERSIDE PLATING

TR-1519 LAYOUT -- BOTTOM VIEW

70-1336

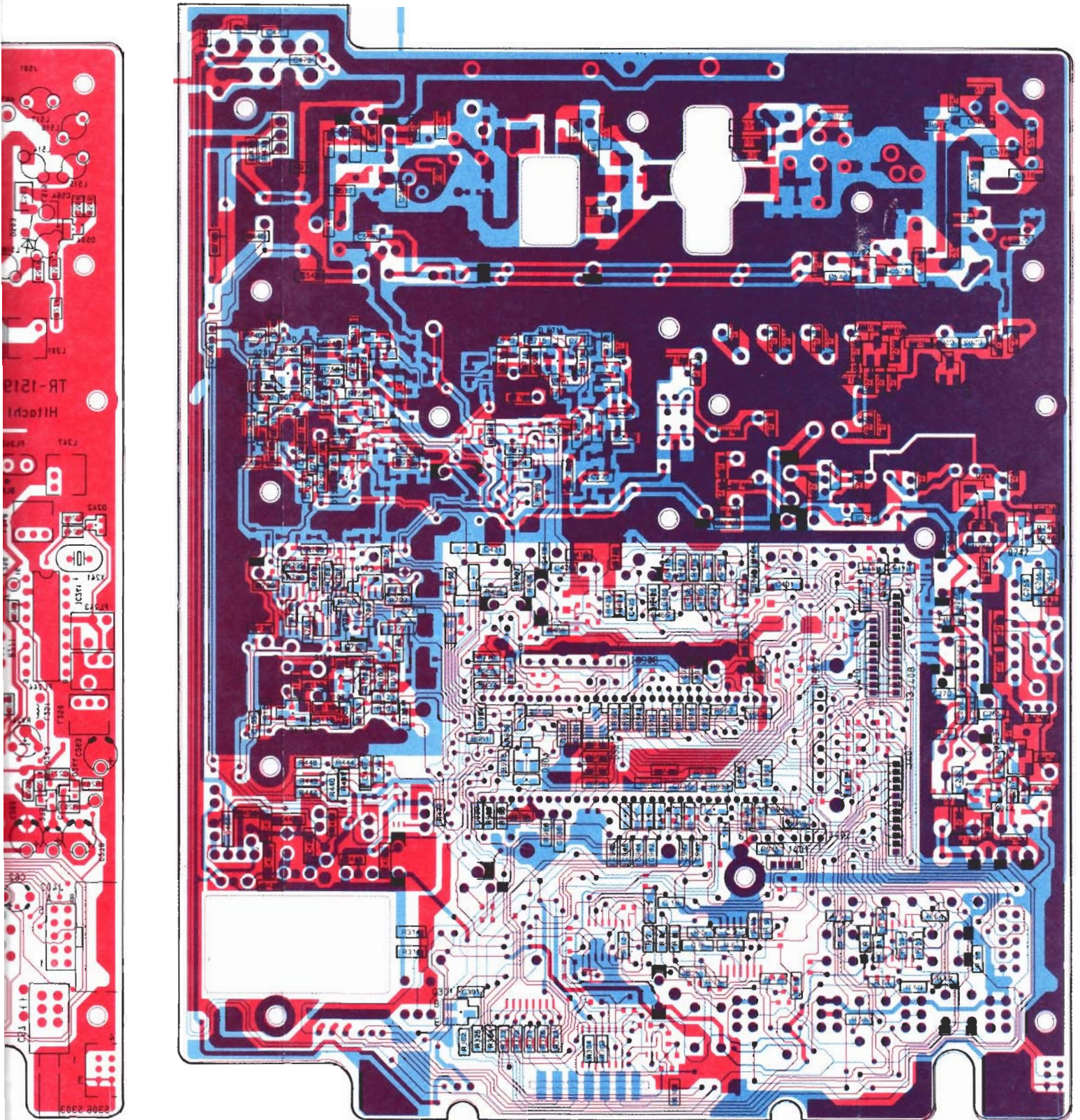

TR-1519 LAYOUT -- TOP VIEW

70-1336

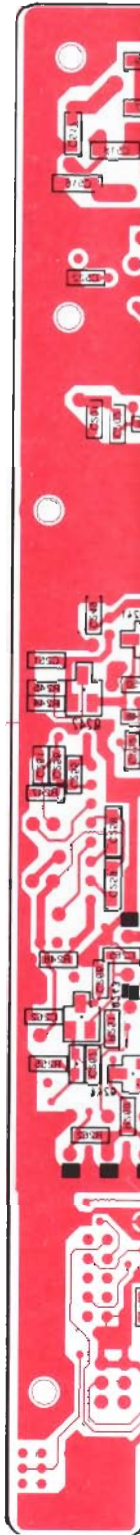
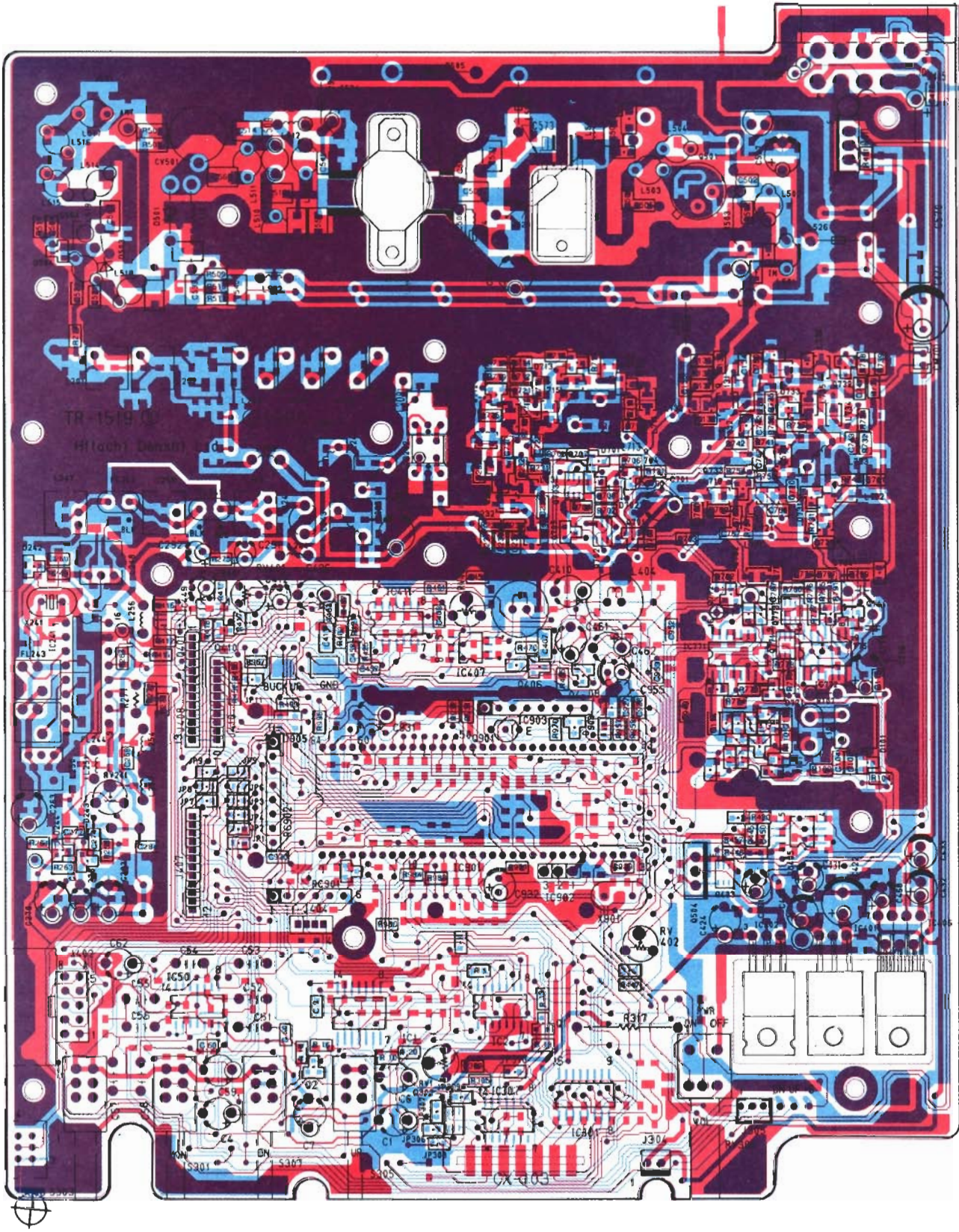

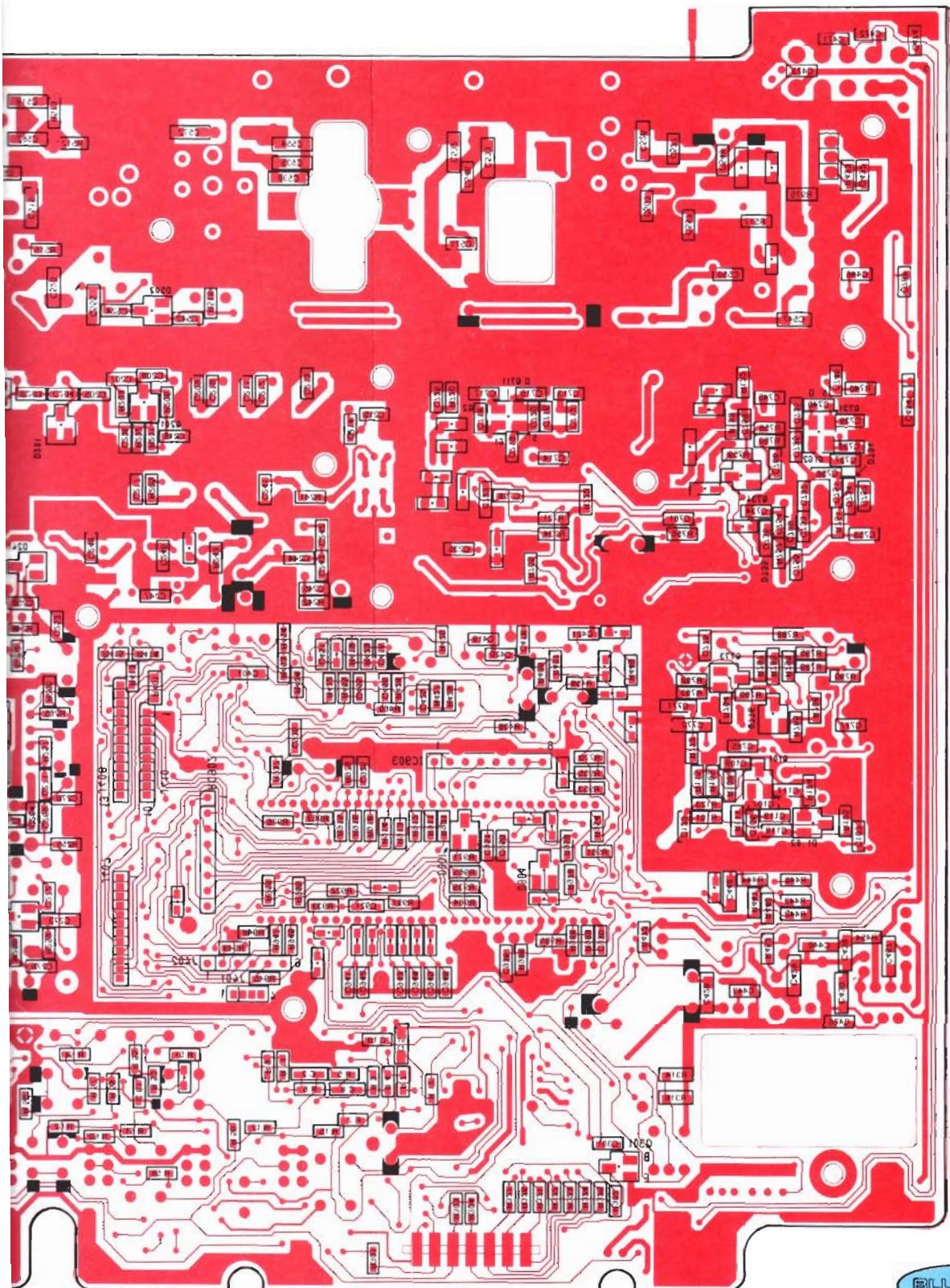

BLUE VISIBLE PLATING
RED UNDERSIDE PLATING

COMPONENT LAYOUT

70-1336

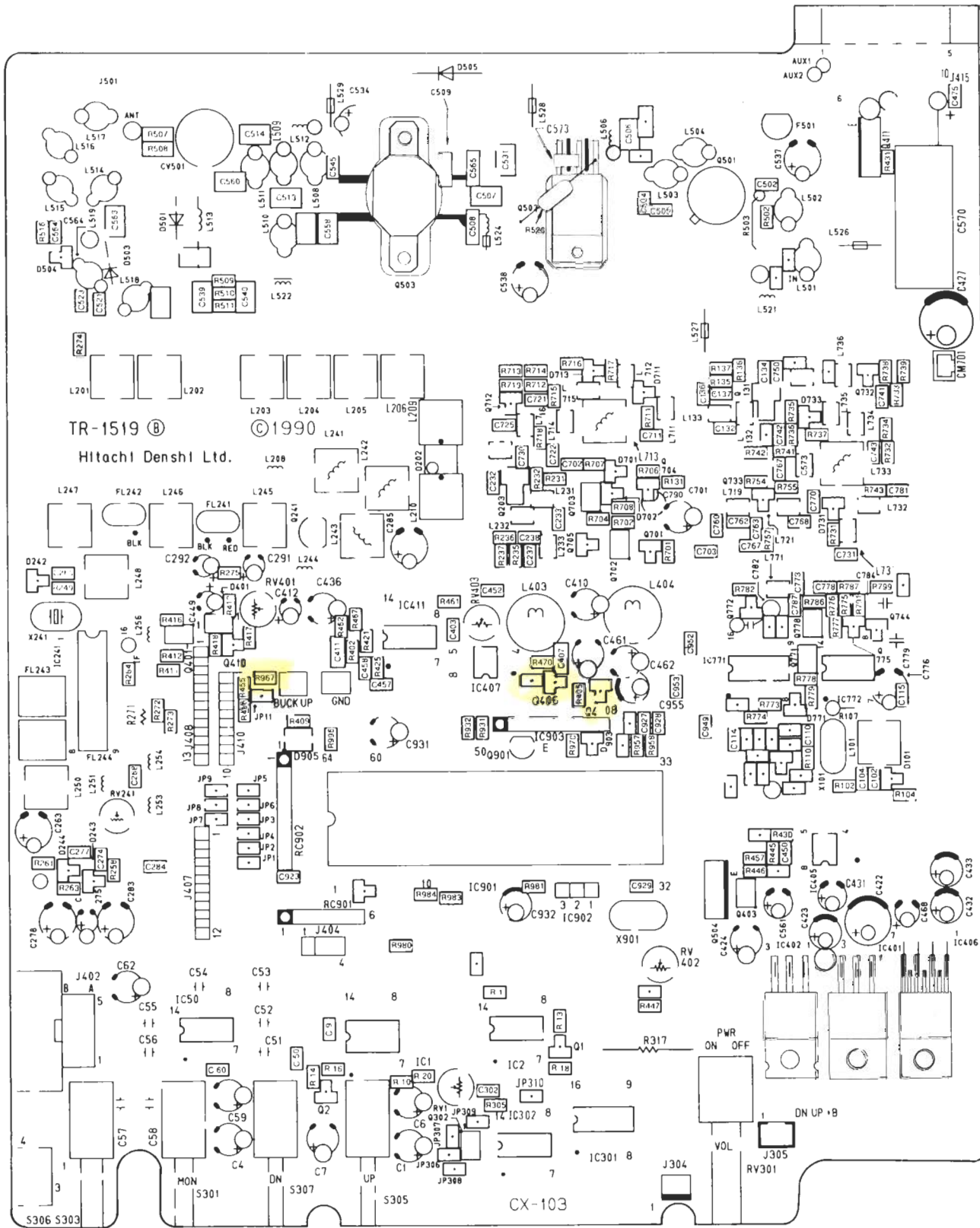

DIODE PINOUTS

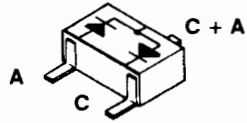

D243, D502

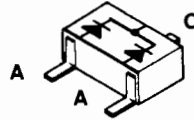

D101, D102, D241, D504,
D711, D713, D731, D733,
D771, D901

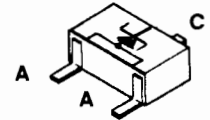

D903

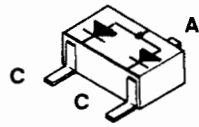

D244, D701, D702, D902,
D904

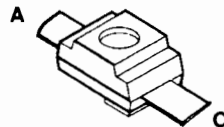

D734, D735

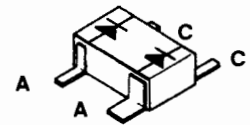

D905

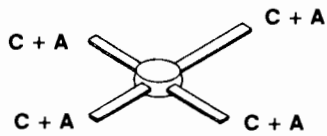

D202

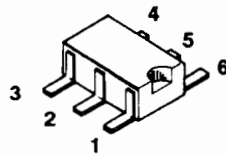

D401

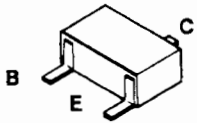

Q1, Q2, Q101, Q201,
Q243, Q244, Q301, Q406,
Q4410, Q701, Q704,
Q705, Q712, Q732, Q733,
Q734, Q772, Q773, Q774,
Q775, Q776

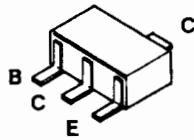

Q131, Q203

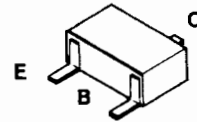

Q702

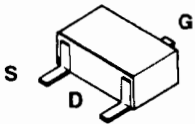

Q408

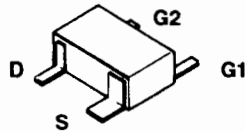

Q711, Q731

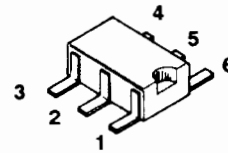

Q302, Q401, Q403,
Q703, Q771, Q778

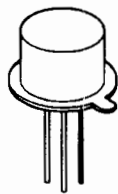

B C E

Q501, Q503



B E C

Q502



E C B

Q504

EXPLODED VIEW

70-1336

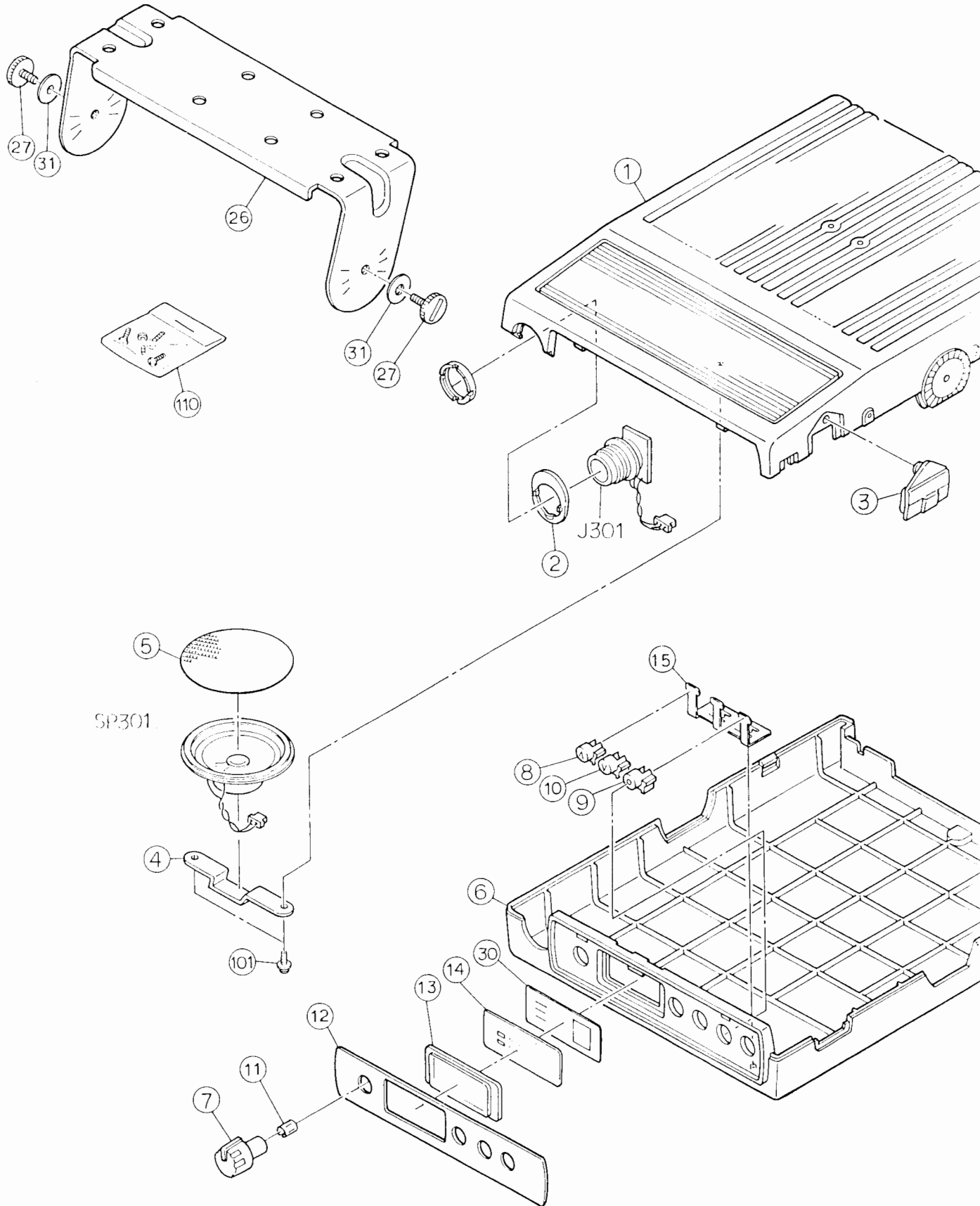

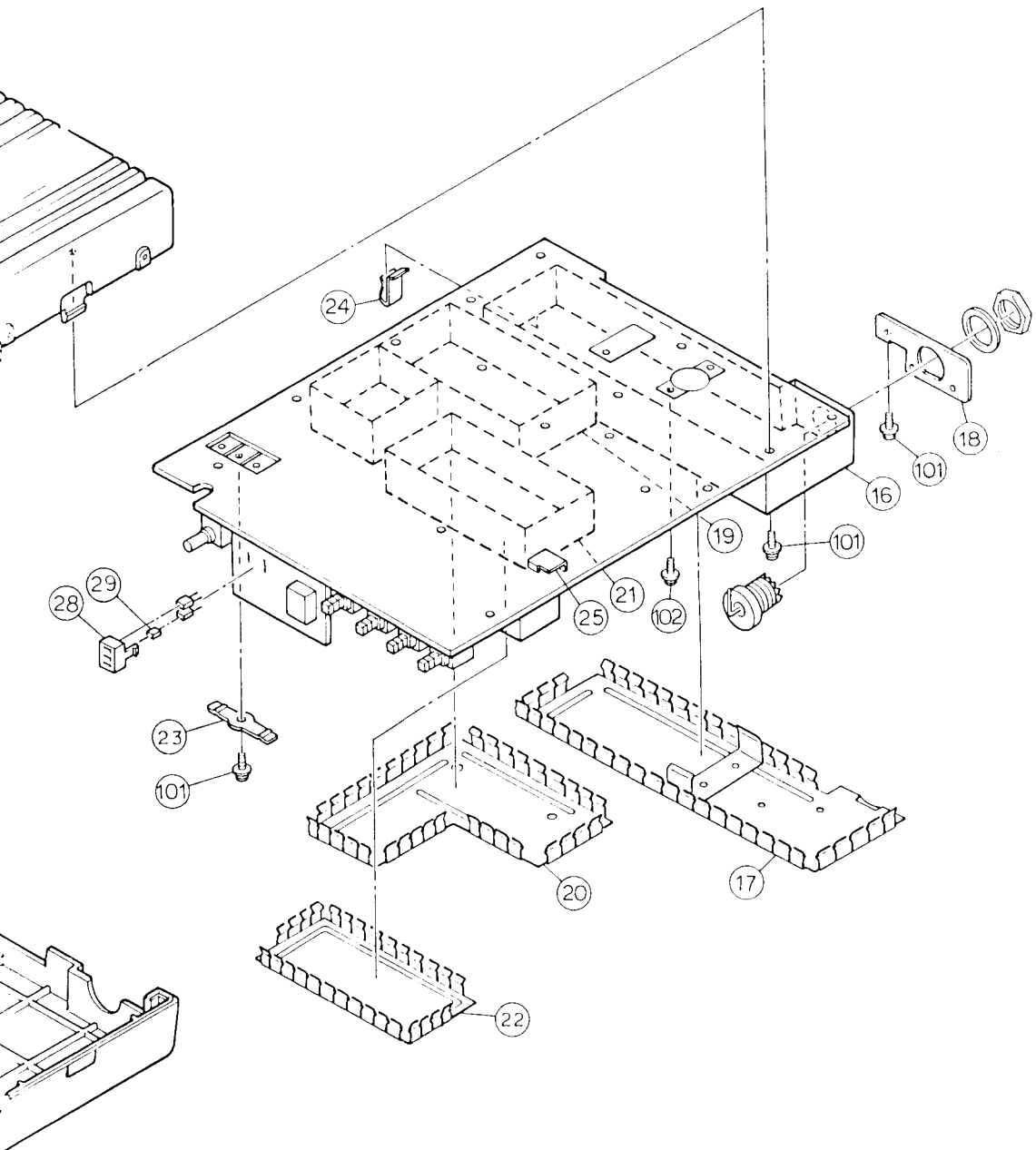

SECTION 7

PARTS

MECHANICAL PARTS

REF NO.	DESCRIPTION	PART NO.
1	CHASSIS	70-010344
2	MIC HOLDER	70-158378
3	ROM CAP	70-157864
4	SP HOLDER	70-158379
5	SP NET	70-157865
6	BOTTOM COVER	70-010346
7	VOLUME KNOB	70-110098
6	SWITCH BUTTON	70-110099
9	SWITCH BUTTON	70-110100
10	SWITCH BUTTON	70-110101
11	KNOB SPRING	70-152127
12	FRONT PANEL	70-010345
13	FILTER	70-020312
14	LED FILM	70-020313
15	SWITCH SPRING	70-152134
16	PA SHIELD CASE	70-089388
17	PA SHIELD COVER	70-089389
18	ANT HOLDER	70-158380
19	VCO SHIELD CASE	70-089341
20	VCO SHIELD COVER	70-089342
21	LOG SHIELD CASE	70-089343
22	LOG SHIELD COVER	70-089390
23	IC HOLDER	70-158383
24	CLIP	70-150128
25	IF SHIELD	70-089349
26	BRACKET	70-158381
27	COIN SCREW	70-150291
28	LED HOLDER	70-158381
29	SILICONE RUBBER	70-157867
30	LEXAN FILM	70-157868
31	WASHER	70-151383
101	SCREW	70-150180
102	SCREW	70-150151
110	FIXED SSCREW	70-151850
G01		TR-1519
G02		CX-104
J301	N51504L	70-159100
J501	M-RM	70-159090
SP301	SPEAKER	70-060037
	POWER CORD 2M	70-034766
	FUSE (135 V, 2A)	70-204028
	MICROPHONE (DYNAMIC)	70-038064

PARTS

70-1336

TR-1519 BOARD

70-1336 TR-1519 Assembly,		A-Band, USE "A"		70-1336 TR-1519 Assembly,		B-Band, USE "B"	
REF NO.	DESCRIPTION	PART NO.	REF NO.	DESCRIPTION	PART NO.	REF NO.	DESCRIPTION
CAPACITORS			CAPACITORS (CONTINUED)				
C1	10 uF, 16 V, AL ELYC	70-138191	C215 A	39 pF, 50 V, CERAMIC	70-138233		
C2	680 pF, 50 V, CERAMIC	70-138152	C215 B	33 pF, 50 V, CERAMIC	70-138188		
C4	10 uF, 16 V, AL ELYC	70-138191	C216 B	0.022 uF, 25 V, CERAMIC	70-138162		
C5	0.1 uF, 25 V, CERAMIC	70-138444	C217 B	1000 pF, 50 V, CERAMIC	70-138255		
C6	10 uF, 16 V, AL ELYC	70-138191	C232 A	27 pF, 50 V, CERAMIC	70-138165		
C7	1 uF, 50 V, AL ELYC	70-138194	C232 B	33 pF, 50 V, CERAMIC	70-138188		
C8	0.022 uF, 25 V, CERAMIC	70-138162	C233	1000 pF, 50 V, CERAMIC	70-138255		
C9	1500 pF, 50 V, CERAMIC	70-138204	C235	56 pF, 50 V, CERAMIC	70-138254		
C10	1500 pF, 50 V, CERAMIC	70-138204	C237	18 pF, 50 V, CERAMIC	70-138206		
C50	0.01 uF, 50 V, CERAMIC	70-138270	C238	22 pF, 50 V, CERAMIC	70-138171		
C51	0.01 uF, 50 V, PLASTIC	70-138224	C241	27 pF, 50 V, CERAMIC	70-138165		
C52	0.01 uF, 50 V, PLASTIC	70-138224	C242	27 pF, 50 V, CERAMIC	70-138165		
C53	0.01 uF, 50 V, PLASTIC	70-138224	C243	82 pF, 50 V, CERAMIC	70-138250		
C54	0.01 uF, 50 V, PLASTIC	70-138224	C244	330 pF, 50 V, CERAMIC	70-138228		
C55	0.01 uF, 50 V, PLASTIC	70-138224	C245	0.01 uF, 50 V, CERAMIC	70-138270		
C56	0.01 uF, 50 V, PLASTIC	70-138224	C246	10 pF, 50 V, CERAMIC	70-138346		
C57	0.01 uF, 50 V, PLASTIC	70-138224	C247	0.01 uF, 50 V, CERAMIC	70-138270		
C58	0.01 uF, 50 V, PLASTIC	70-138224	C248	12 pF, 50 V, CERAMIC	70-138347		
C59	1 uF, 50 V, AL ELYC	70-138194	C249	10 pF, 50 V, CERAMIC	70-138330		
C60	0.01 uF, 50 V, CERAMIC	70-138270	C250	8 pF, 50 V, CERAMIC	70-138203		
C61	0.01 uF, 50 V, CERAMIC	70-138270	C251	0.01 uF, 50 V, CERAMIC	70-138270		
C62	10 uF, 16 V, AL ELYC	70-138191	C252	0.01 uF, 50 V, CERAMIC	70-138270		
C102	47 pF, 50 V, CERAMIC	70-138344	C253	0.01 uF, 50 V, CERAMIC	70-138270		
C103	1000 pF, 50 V, CERAMIC	70-138255	C255	8 pF, 50 V, CERAMIC	70-138203		
C104	100 pF, 50 V, CERAMIC	70-138345	C256	6 pF, 50 V, CERAMIC	70-138348		
C106	22 pF, 50 V, CERAMIC	70-138171	C258	0.1 uF, 25 V, CERAMIC	70-138444		
C107	27 pF, 50 V, CERAMIC	70-138165	C259	0.1 uF, 25 V, CERAMIC	70-138444		
C108	0.022 uF, 25 V, CERAMIC	70-138162	C260	1000 pF, 50 V, CERAMIC	70-138255		
C110	10 pF, 50 V, CERAMIC	70-138330	C261	0.01 uF, 50 V, CERAMIC	70-138270		
C114	47 pF, 50 V, CERAMIC	70-138344	C262	0.01 uF, 50 V, CERAMIC	70-138270		
C115	1000 pF, 50 V, CERAMIC	70-138255	C263	120, uF, 16 V, AL ELYC	70-135167		
C115	1000 pF, 50 V, CERAMIC	70-138255	C264	1000 pF, 50 V, CERAMIC	70-138255		
C117	120 uF, 50 V, CERAMIC	70-138303	C265	4700 pF, 50 V, CERAMIC	70-138163		
C118	120 pF, 50 V, CERAMIC	70-138303	C266	0.01 uF, 50 V, CERAMIC	70-138270		
C119	1000 pF, 50 V, CERAMIC	70-138255	C267	0.01 uF, 50 V, CERAMIC	70-138270		
C122	1000 pF, 50 V, CERAMIC	70-138255	C266	0.022 uF, 25 V, CERAMIC	70-138162		
C132	1000 pF, 50 V, CERAMIC	70-138255	C269	0.01 uF, 50 V, CERAMIC	70-138270		
C134 A	33 pF, 50 V, CERAMIC	70-138188	C270	0.022 uF, 25 V, CERAMIC	70-138162		
C134 B	27 pF, 50 V, CERAMIC	70-138165	C271	0.01 uF, 50 V, CERAMIC	70-138270		
C136	22 pF, 50 V, CERAMIC	70-138171	C272	1000 pF, 50 V, CERAMIC	70-138255		
C137	22 pF, 50 V, CERAMIC	70-138171	C273	0.047 pF, 50 V, CERAMIC	70-131298		
C201	27 pF, 50 V, CERAMIC	70-138165	C274	4700 pF, 50 V, CERAMIC	70-138163		
C202 A	27 pF, 50 V, CERAMIC	70-138165	C275	1.0 uF, 35 V, TA ELYC	70-138087		
C202 B	18 pF, 50 V, CERAMIC	70-138206	C276	0.01 uF, 50 V, CERAMIC	70-138270		
C203 A	8 pF, 50 V, CERAMIC	70-138203	C277	1000 pF, 50 V, CERAMIC	70-138255		
C203 B	8 pF, 50 V, CERAMIC	70-138210	C278	1 uF, 50 V, AL ELYC	70-135147		
C204 A	8 pF, 50 V, CERAMIC	70-138203	C283	47 uF, 25 V, AL ELYC	70-135144		
C204 B	8 pF, 50 V, CERAMIC	70-138210	C284	0.01 uF, 50 V, CERAMIC	70-138270		
C205	39 pF, 50 V, CERAMIC	70-138233	C285	220 uF, 25 V, AL ELYC	70-131300		
C206 A	12 pF, 50 V, CERAMIC	70-138347	C291	47 uF, 25 V, AL ELYC	70-135144		
C206 B	9 pF, 50 V, CERAMIC	70-138138	C292	47 uF, 25 V, AL ELYC	70-135144		
C207 A	39 pF, 50 V, CERAMIC	70-138233	C301	1000 pF, 50 V, CERAMIC	70-138255		
C207 B	27 pF, 50 V, CERAMIC	70-138188	C302	1000 pF, 50 V, CERAMIC	70-138255		
C208 A	39 pF, 50 V, CERAMIC	70-138233	C305	1000 pF, 50 V, CERAMIC	70-138255		
C208 B	27 pF, 50 V, CERAMIC	70-138165	C306	1000 pF, 50 V, CERAMIC	70-138255		
C209 A	100 pF, 50 V, CERAMIC	70-138175	C401	0.1 uF, 25 V, CERAMIC	70-138444		
C209 B	82 pF, 50 V, CERAMIC	70-138250	C403	220 pF, 50 V, AL ELYC	70-138249		
C210 A	27 pF, 50 V, CERAMIC	70-138165	C407	0.047 uF, 50 V, CERAMIC	70-138350		
C210 B	22 pF, 50 V, CERAMIC	70-138171	C410	220 uF, 10 V AL ELECT	70-135217		
C211 A	120 pF, 50 V, CERAMIC	70-138303	C411	0.022 uF, 50 V, CERAMIC	70-138351		
C211 B	100 pF, 50 V, CERAMIC	70-138175	C412	10 uF, 16 V, AL ELYC	70-138191		
C212 A	27 pF, 50 V, CERAMIC	70-138165	C418	82 pF, 50 V, CERAMIC	70-138250		
C212 B	22 pF, 50 V, CERAMIC	70-138171	C418	0.01 uF, 50 V, CERAMIC	70-138270		
C213 A	100 pF, 50 V, CERAMIC	70-138175	C419	0.022 uF, 50 V, CERAMIC	70-132033		
C213 B	82 pF, 50 V, CERAMIC	70-138250	C420	0.047 uF, 50 V, CERAMIC	70-131298		
C214 A	39 pF, 50 V, CERAMIC	70-138233	C421	0.022 uF, 25 V, CERAMIC	70-138162		
C214 B	33 pF, 50 V, CERAMIC	70-138188	C422	220 uF, 25 V, AL ELYC	70-135166		

TR-1519 BOARD (Continued)

REF NO.	DESCRIPTION	PART NO.	REF NO.	DESCRIPTION	PART NO.
CAPACITORS (CONTINUED)			CAPACITORS (CONTINUED)		
C423	10 uF, 18 V, AL ELYC	70-138191	C537	15 uF, 25 V, AL ELYC	70-135154
C424	10 uF, 18 V, AL ELYC	70-138191	C538	10 uF, 50 V, AL ELYC	70-135236
C425	1000 pF, 50 V, CERAMIC	70-138255	C539	1000 pF, 50 V, CERAMIC	70-136073
C426	0.01 uF, 50 V, CERAMIC	70-138270	C540	1000 pF, 50 V, CERAMIC	70-136073
C427	470 uF, 25 V, AL ELYC	70-131305	C542	1000 pF, 50 V, CERAMIC	70-138255
C428	0.1 uF, 25 V, CERAMIC	70-138444	C545	1000 pF, 50 V, CERAMIC	70-138255
C429	0.1 uF, 25 V, CERAMIC	70-138444	C546	1000 pF, 50 V, CERAMIC	70-138255
C430	0.1 uF, 25 V, CERAMIC	70-138444	C547	1000 pF, 50 V, CERAMIC	70-136073
C431	1 uF, 50 V, AL ELYC	70-138194	C548	1000 pF, 50 V, CERAMIC	70-138255
C432	22 uF, 18 V, AL ELYC	70-135220	C549	1000 pF, 50 V, CERAMIC	70-138255
C433	22 uF, 18 V, AL ELYC	70-135220	C550	1000 pF, 50 V, CERAMIC	70-138255
C434	2200 uF, 25 V, AL ELYC	70-135218	C554	0.1 uF, 25 V, CERAMIC	70-138444
C436	220 uF, 10 V AL ELECT	70-135217	C555	33 pF, 50 V, CERAMIC	70-131192
C439	0.1 uF, 25 V, CERAMIC	70-138444	C557	27 pF, 50 V, CERAMIC	70-138185
C440	0.1 uF, 25 V, CERAMIC	70-138444	C558 B	180 pF, 100 V, MICA CHIP	70-138305
C443	0.01 uF, 50 V, CERAMIC	70-138270	C559 A	180 pF, 100 V MICA CHIP	70-138113
C446	1000 pF, 50 V, CERAMIC	70-138255	C559 B	150 pF, 500 V, CERAMIC	70-138111
C448	0.1 uF, 25 V, CERAMIC	70-138444	C560	1000 pF, 100 V, CERAMIC	70-138239
C449	47 uF, 18 V, TA ELYC	70-135149	C561	10 uF, 25 V, AL ELYC	70-135173
C450	1000 pF, 50 V, CERAMIC	70-138255	C563	1000 pF, 100 V, CERAMIC	70-138239
C451	82 pF, 50 V, CERAMIC	70-138250	C564	1000 pF, 50 V, CERAMIC	70-138255
C452	0.022 uF, 25 V, CERAMIC	70-138182	C565 A	220 pF, 100 V, CERAMIC	70-138261
C457	220 pF, 50 V, CERAMIC	70-138349	C565 B	150 pF, 500 V, CERAMIC	70-138258
C458	220 pF, 50 V, CERAMIC	70-138349	C587	1000 pF, 100 V, CERAMIC	70-138239
C461	10 uF, 18 V, AL ELYC	70-138191	C570	2200 uF, 25 V, AL ELYC	70-135235
C462	10 uF, 18 V, AL ELYC	70-138191	C571	1000 pF, 50 V, CERAMIC	70-138255
C465	100 pF, 50 V, CERAMIC	70-138175	C572 B	1000 pF, 50 V, CERAMIC	70-131205
C466	220 pF, 50 V, CERAMIC	70-138349	C573 A	47 pF, 500 V, CERAMIC	70-138283
C467	0.1 uF, 25 V, CERAMIC	70-138444	C573 B	33 pF, 50 V, CERAMIC	70-138162
C471	1000 pF, 50 V, CERAMIC	70-138255	C701	100 uF, 18 V, AL ELYC	70-138184
C472	1000 pF, 50 V, CERAMIC	70-138255	C702	0.022 uF, 25 V, CERAMIC	70-138162
C473	1000 pF, 50 V, CERAMIC	70-138255	C703	1000 pF, 50 V, CERAMIC	70-138255
C474	1000 pF, 50 V, CERAMIC	70-138255	C711	1000 pF, 50 V, CERAMIC	70-138255
C475	1000 pF, 50 V, CERAMIC	70-138255	C712 A	27 pF, 50 V, CERAMIC	70-138185
C502	56 pF, 50 V, CERAMIC	70-138254	C712 B	22 pF, 50 V, CERAMIC	70-138171
C503	15 pF, 50 V, CERAMIC	70-138205	C713 A	4 pF, 50 V, CERAMIC	70-138179
C504 A	120 pF, 50 V, CERAMIC	70-138303	C713 B	8 pF, 50 V, CERAMIC	70-138210
C504 B	88 pF, 50 V, CERAMIC	70-138229	C714 A	220 pF, 50 V, CERAMIC	70-138349
C505 B	56 pF, 50 V, CERAMIC	70-138254	C714 B	1000 pF, 50 V, CERAMIC	70-138255
C506 A	100 pF, 50 V, CERAMIC	70-132051	C715	2 pF, 50 V, CERAMIC	70-138169
C506 B	120 pF, 50 V CER	70-132057	C718	15 pF, 50 V, CERAMIC	70-138205
C507 A	150 pF, 500 V, CERAMIC	70-138258	C717	1000 pF, 50 V, CERAMIC	70-138255
C507 B	150 pF, 500 V, CERAMIC	70-138258	C718	1000 pF, 50 V, CERAMIC	70-138255
C508	220 pF, 100 V, MICA	70-138112	C719 A	15 pF, 50 V, CERAMIC	70-138205
C509	220 pF, 100 V, CERAMIC	70-138261	C719 B	10 pF, 50 V, CERAMIC	70-138187
C512 A	82 pF, 500 V, CERAMIC	70-138259	C720 A	15 pF, 50 V, CERAMIC	70-138205
C512 B	88 pF, 500 V, CERAMIC	70-138288	C720 B	10 pF, 50 V, CERAMIC	70-138187
C513	220 pF, 100 V, MICA	70-138112	C721	2 pF, 50 V, CERAMIC	70-138169
C514	56 pF, 500 V, CERAMIC	70-138285	C722	1000 pF, 50 V, CERAMIC	70-138255
C515 A	10 pF, 500 V, CERAMIC	70-138353	C723	0.022 uF, 25 V, CERAMIC	70-138253
C515 B	12 pF, 500 V, CERAMIC	70-138266	C725	1000 pF, 50 V, CERAMIC	70-138255
C516	27 pF, 500 V, CERAMIC	70-138305	C726	1000 pF, 50 V, CERAMIC	70-138255
C517 A	33 pF, 500 V, CERAMIC	70-138262	C730	100 pF, 50 V, CERAMIC	70-138175
C517 B	27 pF, 500 V, CERAMIC	70-138305	C731	1000 pF, 50 V, CERAMIC	70-138255
C518 A	33 pF, 500 V, CERAMIC	70-138262	C732	39 pF, 50 V, CERAMIC	70-138233
C518 B	27 pF, 500 V, CERAMIC	70-138305	C733 A	1 pF, 50 V, CERAMIC	70-138174
C519	12 pF, 500 V, CERAMIC	70-138266	C733 B	4 pF, 50 V, CERAMIC	70-138179
C520	12 pF, 500 V, CERAMIC	70-138266	C734	100 pF, 50 V, CERAMIC	70-138230
C521	22 pF, 50 V, CERAMIC	70-138171	C735	2 pF, 50 V, CERAMIC	70-138169
C522	6 pF, 50 V, CERAMIC	70-138210	C738 A	15 pF, 50 V, CERAMIC	70-138205
C523	1000 pF, 50 V, CERAMIC	70-138255	C738 B	22 pF, 50 V, CERAMIC	70-138171
C524	1000 pF, 50 V, CERAMIC	70-138255	C737	0.022 uF, 25 V, CERAMIC	70-138162
C526	1000 pF, 50 V, CERAMIC	70-138073	C738	1000 pF, 50 V, CERAMIC	70-138255
C527	0.01 uF, 50 V, CERAMIC	70-138270	C739 A	15 pF, 50 V, CERAMIC	70-138205
C531	1000 pF, 100 V, CERAMIC	70-138239	C739 B	10 pF, 50 V, CERAMIC	70-138187
C532	0.1 uF, 25 V, CERAMIC	70-138444	C740 A	15 pF, 50 V, CERAMIC	70-138205
C533	0.01 uF, 50 V, CERAMIC	70-131297	C740 B	10 pF, 50 V, CERAMIC	70-138187
C534	15 uF, 50 V, CERAMIC	70-138154	C741	2 pF, 50 V, CERAMIC	70-138169
C535	1000 pF, 100 V, CERAMIC	70-138239	C742	0.022 uF, 25 V, CERAMIC	70-138162
C536	0.047 pF, 50 V, CERAMIC	70-131298	C743	1000 pF, 50 V, CERAMIC	70-138255

TR-1519 BOARD (Continued)

REF NO.	DESCRIPTION	PART NO.	REF NO.	DESCRIPTION	PART NO.
CAPACITORS (CONTINUED)			DIODES		
C745	1000 pF, 50 V, CERAMIC	70-138255	D101	KV1430TR01-34	70-085312
C746	1000 pF, 50 V, CERAMIC	70-138255	D102	KV1430TR01-34	70-085312
C750	100 pF, 50 V, CERAMIC	70-138175	D201	DCC010-TA	70-085313
C751	3 pF, 50 V, CERAMIC	70-138164	D202	ND487C2-3R	70-085228
C752	18 pF, 50 V CER	70-138208	D241	MA704-TW	70-085247
C753	1000 pF, 50 V, CERAMIC	70-138255	D242	MA3068-M TW	70-085273
C754 A	22 pF, 50 V CER	70-138171	D243	HSM88S	70-085154
C754 B	18 pF, 50 V, CER	70-138208	D244	DCA010-TA	70-085250
C755	1000 pF, 50 V, CERAMIC	70-138255	D401	IMN10	70-085314
C756	3 pF, 50 V, CERAMIC	70-138164	D501	MI407	70-085047
C758	2 pF, 50 V, CERAMIC	70-138175	D502	HSM88S	70-085154
C759	2 pF, 50 V, CERAMIC	70-138175	D503	MI407	70-085152
C760	1000 pF, 50 V, CERAMIC	70-138255	D504	MA704A-TW	70-085247
C761	1000 pF, 50 V, CERAMIC	70-138255	D505	U05C	70-085158
C762 A	3 pF, 50 V, CERAMIC	70-138480	D701	DCA010-TA	70-085250
C762 B	2 pF, 50 V, CERAMIC	70-138175	D702	DCA010-TA	70-085250
C763	2 pF, 50 V, CERAMIC	70-138175	D711	KV1430TR01-34	70-085312
C766	1000 pF, 50 V, CERAMIC	70-138255	D713	MA704A	70-085247
C766	2 pF, 50 V, CERAMIC	70-138169	D731	KV1430TR01-34	70-085312
C769 A	27 pF, 50 V, CERAMIC	70-138233	D733	MA704A	70-085247
C769 B	27 pF, 50 V, CERAMIC	70-138171	D734	1SV168	70-085159
C770 A	2 pF, 50 V, CERAMIC	70-138179	D735	1SV168	70-085159
C770 B	3 pF, 50 V, CERAMIC	70-138164	D771	DCB010-TA	70-085245
C771	0.022 uF, 25 V, CERAMIC	70-138182	D901	DCB010-TA	70-085245
C772	0.1 uF, 25 V, CERAMIC	70-138444	D902	DCA010-TA	70-085250
C773 A	6 pF, 50 V, CERAMIC	70-138210	D903	HZM6A	70-085230
C773 B	4 pF, 50 V, CERAMIC	70-138179	D904	DCA010	70-085250
C775	0.022 uF, 25 V, CERAMIC	70-138182	D905	DWA010-TF	70-085248
C776	47 uF, 25 V, AL ELYC	70-135144			
C777	1000 pF, 50 V, CERAMIC	70-138255		FILTERS	
C778	0.022 uF, 25 V, CERAMIC	70-138182	FL241	45N14BA 45.000 MHZ	70-179091
C779	0.1 uF, 50 V, PLASTIC	70-138189	FL243	CFU455E2	70-179019
C781	1000 pF, 50 V, CERAMIC	70-138255	FL244	CFU-455D2	70-179018
C782	1 uF, 50 V, PLASTIC	70-137101			
C783	0.022 uF, 25 V, CERAMIC	70-138182		INTEGRATED CIRCUITS	
C784	0.1 uF, 50 V, PLASTIC	70-138189	IC1	MF8CWN-50	70-076611
C785	0.022 uF, 25 V, CERAMIC	70-138182	IC2	BU4068BF-T1	70-076573
C787	1000 pF, 50 V, CERAMIC	70-138255	IC50	BA10324F-T1	70-076612
C788	1000 pF, 50 V, CERAMIC	70-138255	IC241	MC3361P	70-076454
C789 A	12 pF, 50 V, CERAMIC	70-138209	IC301	MC14511BFP	70-076674
C789 B	8 pF, 50 V, CERAMIC	70-138203	IC302	BU74HC74F	70-076675
C790	47 uF, 16 V, AL ELYC	70-138200	IC401	AN6541	70-076468
C921	0.022 uF, 25 V, CERAMIC	70-138182	IC402	HA17805W	70-076567
C923	1000 pF, 50 V, CERAMIC	70-138255	IC405	BA728F	70-076569
C925	0.01 uF, 50 V, CERAMIC	70-138270	IC406	TDA7240AH	70-076688
C928	220 pF, 50 V, CERAMIC	70-138349	IC407	BA728F	70-076569
C929	22 pF, 50 V, CERAMIC	70-138171	IC411	BA10324F-T1	70-076612
C930	47 pF, 50 V, CERAMIC	70-138165	IC771	MB1504PF-G-BND-TF	70-076598
C931	10 uF, 16 V, AL ELYC	70-138191	IC772	BU4068BF	70-076649
C932	1 uF, 50 V, AL ELYC	70-138194	IC901	M37450M4-378SP	70-076678
C935	0.022 uF, 25 V, CERAMIC	70-138182	IC902	MN1280R	70-076575
C936	0.01 uF, 50 V, CERAMIC	70-138270	IC903	M6M8002IL	70-076576
C941	220 pF, 50 V, CERAMIC	70-138349			
C942	220 pF, 50 V, CERAMIC	70-138349		JACKS	
C943	220 pF, 50 V, CERAMIC	70-138349	J301	NS1504L	70-158100
C944	220 pF, 50 V, CERAMIC	70-138349	J304	IL-G-2P-S3T2-E	70-158565
C945	220 pF, 50 V, CERAMIC	70-138349	J305	IL-G-3P-S3T2-E	70-158707
C946	220 pF, 50 V, CERAMIC	70-138349	J401	IL-S-P-S2T2-EF	70-158558
C949	1000 pF, 50 V, CERAMIC	70-138255	J402	PS-10PE-D4T1-B1	70-158428
C950	220 pF, 50 V, CERAMIC	70-138349	J415	5569-10A1	70-158709
C951	220 pF, 50 V, CERAMIC	70-138349			
C952	0.01 uF, 50 V, CERAMIC	70-138270			
C953	0.01 uF, 50 V, CERAMIC	70-138270			
C955	1 uF, 50 V, AL ELYC	70-138194			
VARIABLE CAPACITORS					
CV501	2222-808-32409	70-123024			

TR-1519 BOARD (Continued)

REF NO.	DESCRIPTION	PART NO.	REF NO.	DESCRIPTION	PART NO.
JUMPERS			COILS (CONTINUED)		
JP1	0 OHM, 1/10 W, METAL	70-144106	L528	BL01RN-A62B1	70-090560
JP2	0 OHM, 1/10 W, METAL	70-144106	L529	BL01RN-A62B1	70-090560
JP3	0 OHM, 1/10 W, METAL	70-144106	L711	LQH3N2R2M020M00-100	70-090477
JP6	0 OHM, 1/10 W, METAL	70-144106	L712	LQH3N2R2M020M00-100	70-090477
JP7	0 OHM, 1/10 W, METAL	70-144106	L713 A	L-1S7-M1, 2.5 T VSF	70-090534
JP8	0 OHM, 1/10 W, METAL	70-144106	L713 B	L-1S7-M1, 2.5 T	70-090501
JP9	0 OHM, 1/10 W, METAL	70-144106	L714	LQH3N2R2M020M00-100	70-090477
JP11	100 OHM, 1/10 W, METAL	70-144321	L715	LQH3N2R2M020M00-100	70-090477
JP306	0 OHM, 1/10 W, METAL	70-144106	L716	LQN2A2R22K	70-090483
JP307	0 OHM, 1/10 W, METAL	70-144106	L719	LQN2A22NM	70-090412
JP308	0 OHM, 1/10 W, METAL	70-144106	L721	LQN2A47NM	70-090464
JP309	0 OHM, 1/10 W, METAL	70-144106	L731	LQH3N2R2M020M00-100	70-090477
COILS			L733 A	L-1S7-M1 3.5 T VSF	70-090523
L101	42L060	70-090462	L733 B	L-1S7-M1 3.5 T	70-090522
L132	LQN2AR22K	70-090463	L734	LQH3N2R2M020M00-100	70-090477
L133	LQN2A47NM	70-090464	L735 A	LQN2AR22K	70-090483
L201	L-1S7-M1, 4.5 T	70-090465	L735 B	LQH3N2R2M020M00-100	70-090477
L202	L-1S7-M1, 4.5 T	70-090465	L771	LQN2A22NM	70-090412
L203	L-1S7-M1, 4.5 T	70-090465	TRANSISTORS		
L204	L-1S7-M1, 4.5 T	70-090465	Q1	2SC2462-TR(LC)	70-080288
L205	L-1S7-M1, 4.5 T	70-090465	Q2	2SC2462C-T4(LC)	70-080288
L206	L-1S7-M1, 4.5 T	70-090465	Q101	2SC2802B-TR (QB)	70-080181
L208	ELESN4R7KA	70-090466	Q131	2SC3357-T2	70-080298
L209	17L004	70-090114	Q201	2SC3356-T2	70-080280
L210	17L004	70-090114	Q203	2SC3357-T2	70-080298
L231	LQN2AR22K	70-090463	Q243	2SC2462-TR (LC)	70-080288
L232	LQN2A22NM	70-090412	Q244	2SC2462-TR (LC)	70-080288
L233	LQN2A22NM	70-090412	Q301	DTC124EK-T1	70-080300
L241	ELESN4R7MA	70-090468	Q302	IMH1-T1	70-080296
L242	ELESN4R7MA	70-090468	Q401	IMX2-T108 (X2)	70-080363
L243	ELESN4R7MA	70-090468	Q403	IMX2-T108 (X2)	70-080363
L244	ELESN4R7KA	70-090466	Q406	2SC2462-TR (LC)	70-080288
L245	24L113	70-090470	Q408	2SK508	70-080191
L246	42L061	70-090471	Q410	2SC2462-TR (LC)	70-080288
L247	24L116	70-090472	Q501	2N4427	70-080147
L248	24L115	70-090473	Q502	2SC1971	70-080054
L250	41L001	70-090423	Q503	2SC2630	70-080091
L251	ELESN102KA	70-090474	Q504	2SB1085Q	70-080367
L253	ELESN331KA	70-090476	Q701	2SC2462C-TR	70-080288
L254	ELESN331KA	70-090476	Q702	IMB3-T110	70-080364
L256	ELESN4R7KA	70-090466	Q703	IMH1-T1	70-080296
L403	FS1012S-174K	70-178055	Q704	2SA1121C	70-080339
L404	FS1012S-174K	70-178055	Q705	DTC124EK	70-080300
L501	S5.5T	70-090478	Q711	3SK151GR	70-080303
L502	S4.5T	70-090489	Q712	2SC2351	70-080218
L503	S3.5T	70-090491	Q731	3SK151GR	70-080303
L504	S1.5T	70-090495	Q732	2SC2351	70-080218
L506	BL02RN1-R62	70-090122	Q733	2SC2351	70-080218
L508	S4.5T	70-090489	Q734	2SC2351	70-080218
L509	S1.5T	70-090495	Q771	IMD3-T1	70-080297
L510 A	S3.5T	70-090494	Q772	DTC124EK	70-080274
L510 B	S2.5T	70-090490	Q773	2SC2462-TR (LC)	70-080288
L511 A	S2.5T	70-090490	Q774	2SA1121C	70-080339
L511 B	S2.5T	70-090487	Q775	2SA1121C	70-080339
L512	BL02RN1-R62	70-090122	Q776	2SC2462-TR (LC)	70-080288
L513	0.47 uH ±10%	70-090493	Q778	IMH1-T1	70-080296
L514	C4.5T	70-090488	RESISTORS		
L515	C4.5T	70-090488	R1	10 KOHM, 1/10 W, METAL	70-144120
L516	C4.5T	70-090488	R2	12 KOHM, 1/10 W, METAL	70-144111
L517	C4.5T	70-090488	R3	10 KOHM, 1/10 W, METAL	70-144120
L518 A	C8.5T	70-090481	R4	100 KOHM, 1/10 W, METAL	70-144321
L518 B	C5.5T	70-090486	R5	100 KOHM, 1/10 W, METAL	70-144321
L519	C6.5T	70-090187	R6	150 KOHM, 1/10 W, METAL	70-144128
L521	ELESN1FROMA	70-090480	R7	220 KOHM, 1/10 W, METAL	70-144131
L522	ELESN1FROMA	70-090480	R8	1 KOHM, 1/10 W, METAL	70-144125
L524	ZB08C5D 2.5 T	70-090049	R10	27 KOHM, 1/10 W, METAL	70-144163
L526	BL01RN-A62B1	70-090560			
L527	BL01RN-A62B1	70-090560			

TR-1519 BOARD (Continued)

REF NO.	DESCRIPTION	PART NO.	REF NO.	DESCRIPTION	PART NO.
RESISTORS (CONTINUED)			RESISTORS (CONTINUED)		
R11	470 KOHM, 1/10 W, METAL	70-144199	R261	3.3 KOHM, 1/10 W, METAL	70-144118
R12	1 KOHM, 1/10 W, METAL	70-144125	R262	82 KOHM, 1/10 W, METAL	70-144173
R13	22 KOHM, 1/10 W, METAL	70-144121	R263	10 KOHM, 1/10 W, METAL	70-144120
R14	3.3 KOHM, 1/10 W, METAL	70-144118	R264	27 KOHM, 1/10 W, METAL	70-144163
R15	1 KOHM, 1/10 W, METAL	70-144125	R265	15 KOHM, 1/10 W, METAL	70-145122
R16	1 KOHM, 1/10 W, METAL	70-144125	R266	47 KOHM, 1/10 W, METAL	70-145145
R17	39 KOHM, 1/10 W, METAL	70-144196	R271	10 KOHM, METAL	70-144423
R18	22 KOHM, 1/10 W, METAL	70-144121	R272	10 KOHM, 1/10 W, METAL	70-144120
R20	100 KOHM, 1/10 W, METAL	70-144321	R273	4.7 KOHM, 1/10 W, METAL	70-144123
R50	820 OHM, 1/10 W, METAL	70-144185	R274	0 OHM, 1/10 W, METAL	70-144106
R51	24 KOHM, 1/10 W, METAL	70-144306	R275	33 OHM, 1/10 W, METAL	70-140320
R53	27 KOHM, 1/10 W, METAL	70-144163	R301	680 OHM, 1/10 W, METAL	70-144157
R54	4.3 KOHM, 1/10 W, METAL	70-144307	R302	22 OHM, 1/10 W, METAL	70-144121
R55	580 KOHM, 1/10 W, METAL	70-144306	R303	270 OHM, 1/10 W, METAL	70-144116
R56	18 KOHM, 1/10 W, METAL	70-144195	R304	270 OHM, 1/10 W, METAL	70-144118
R57	56 KOHM, 1/10 W, METAL	70-144169	R305	220 KOHM, 1/10 W, METAL	70-144131
R58	12 KOHM, 1/10 W, METAL	70-144111	R314	150 OHM, 1/8 W, METAL	70-144011
R59	150 KOHM, 1/10 W, METAL	70-144129	R316	150 OHM, 1/8 W, METAL	70-144011
R60	270 OHM, 1/10 W, METAL	70-144116	R317	7.5 OHM, 3 W, METAL	70-144424
R61	180 KOHM, 1/10 W, METAL	70-144309	R401	270 OHM, 1/4 W, METAL	70-144193
R62	100 OHM, 1/10 W, METAL	70-144123	R402	22 KOHM, 1/10 W, METAL	70-144121
R101	47 KOHM, 1/10 W, METAL	70-145145	R404	33 KOHM, 1/10 W, METAL	70-144112
R102	47 KOHM, 1/10 W, METAL	70-145145	R405	1 KOHM, 1/10 W, METAL	70-144125
R104	47 KOHM, 1/10 W, METAL	70-145145	R406	100 KOHM, 1/10 W, METAL	70-144321
R107	1 KOHM, 1/10 W, METAL	70-144266	R407	100 KOHM, 1/10 W, METAL	70-144321
R108	10 KOHM, 1/10 W, METAL	70-144120	R408	100 KOHM, 1/10 W, METAL	70-144321
R109	4.7 KOHM, 1/10 W, METAL	70-144123	R409	100 KOHM, 1/10 W, METAL	70-144321
R110	2.2 KOHM, 1/10 W, METAL	70-144113	R410	33 KOHM, 1/10 W, METAL	70-144112
R111	1.5 KOHM, 1/10 W, METAL	70-144134	R411	22 KOHM, 1/10 W, METAL	70-144121
R115	100 OHM, 1/10 W, METAL	70-145146	R412	10 KOHM, 1/10 W, METAL	70-144120
R123	220 KOHM, 1/10 W, METAL	70-144131	R413	1 KOHM, 1/10 W, METAL	70-144125
R124	47 KOHM, 1/10 W, METAL	70-145145	R414	15 KOHM, 1/10 W, METAL	70-144122
R125	47 KOHM, 1/10 W, METAL	70-145145	R415	150 KOHM, 1/10 W, METAL	70-144129
R131	10 OHM, 1/10 W, METAL	70-144115	R416	68 KOHM, 1/10 W, METAL	70-144119
R132	470 OHM, 1/10 W, METAL	70-144152	R417	4.7 KOHM, 1/10 W, METAL	70-144123
R133	10 KOHM, 1/10 W, METAL	70-144120	R418	100 OHM, 1/10 W, METAL	70-145136
R135	220 OHM, 1/10 W, METAL	70-144194	R419	220 KOHM, 1/10 W, METAL	70-144131
R136	22 OHM, 1/10 W, METAL	70-144160	R421	22 KOHM, 1/10 W, METAL	70-144121
R137	220 OHM, 1/10 W, METAL	70-144194	R422	22 KOHM, 1/10 W, METAL	70-144121
R201	33 KOHM, 1/10 W, METAL	70-144112	R423	100 KOHM, 1/10 W, METAL	70-144321
R202	8.2 KOHM, 1/10 W, METAL	70-140305	R425	12 KOHM, 1/10 W, METAL	70-144111
R203	10 OHM, 1/10 W, METAL	70-144115	R426	47 KOHM, 1/10 W, METAL	70-145145
R205	88 OHM, 1/10 W, METAL	70-144114	R427	47 KOHM, 1/10 W, METAL	70-145145
R206 A	56 OHM, 1/10 W, METAL	70-145142	R428	680 OHM, 1/10 W, METAL	70-144157
R206 B	47 OHM, 1/10 W, METAL	70-145130	R429	2.7 KOHM, 1/10 W, METAL	70-144239
R231	470 OHM, 1/10 W, METAL	70-144152	R430	1 KOHM, 1/10 W, METAL	70-144125
R232	10 KOHM, 1/10 W, METAL	70-144120	R431	33 OHM, 1/10 W, METAL	70-140320
R234	22 OHM, 1/10 W, METAL	70-144160	R432	33 OHM, 1/10 W, METAL	70-140320
R235 A	180 OHM, 1/10 W, METAL	70-144150	R433	33 OHM, 1/10 W, METAL	70-140320
R235 B	270 OHM, 1/10 W, METAL	70-144116	R440	150 KOHM, 1/10 W, METAL	70-144287
R236 A	27 OHM, 1/10 W, METAL	70-144219	R441	100 KOHM, 1/10 W, METAL	70-144268
R236 B	18 OHM, 1/10 W, METAL	70-144171	R442	1 KOHM, 1/10 W, METAL	70-144289
R237 A	180 OHM, 1/10 W, METAL	70-144150	R443	39 KOHM, 1/10 W, METAL	70-144290
R237 B	270 OHM, 1/10 W, METAL	70-144116	R444	82 KOHM, 1/10 W, METAL	70-144291
R241	47 OHM, 1/10 W, METAL	70-145130	R445	100 KOHM, 1/10 W, METAL	70-144321
R242	220 OHM, 1/10 W, METAL	70-144194	R446	2.2 KOHM, 1/10 W, METAL	70-144113
R243	3.3 KOHM, 1/10 W, METAL	70-144118	R447	3.9 KOHM, 1/10 W, METAL	70-144132
R244	10 KOHM, 1/10 W, METAL	70-144120	R448	10 KOHM, 1/10 W, METAL	70-144120
R245	330 OHM, 1/10 W, METAL	70-144164	R449	2.7 KOHM, 1/10 W, METAL	70-144159
R246	1 KOHM, 1/10 W, METAL	70-145125	R452	330 OHM, 1/8 W, METAL	70-144065
R247	33 KOHM, 1/10 W, METAL	70-144112	R454	10 OHM, 1/8 W, METAL	70-144068
R248	22 KOHM, 1/10 W, METAL	70-144121	R455	10 KOHM, 1/10 W, METAL	70-144120
R249	150 OHM, 1/10 W, METAL	70-140321	R456	10 KOHM, 1/10 W, METAL	70-144120
R251	1 KOHM, 1/10 W, METAL	70-145125	R457	2.2 KOHM, 1/10 W, METAL	70-144113
R255	1.2 KOHM, 1/10 W, METAL	70-144167	R458	330 OHM, 1/10 W, METAL	70-144164
R256	82 KOHM, 1/10 W, METAL	70-144173	R461	1 KOHM, 1/10 W, METAL	70-144125
R257	47 KOHM, 1/10 W, METAL	70-145145	R462	3.3 KOHM, 1/10 W, METAL	70-144118
R258	220 KOHM, 1/10 W, METAL	70-144131	R463	470 OHM, 1/10 W, METAL	70-144152
R259	1 KOHM, 1/10 W, METAL	70-144125	R464	2.2 KOHM, 1/10 W, METAL	70-144113
R260	5.6 KOHM, 1/10 W, METAL	70-144168	R465	220 KOHM, 1/10 W, METAL	70-144131

TR-1519 BOARD (Continued)

REF NO.	DESCRIPTION	PART NO.	REF NO.	DESCRIPTION	PART NO.
RESISTORS (CONTINUED)			RESISTORS (CONTINUED)		
R466	47 KOHM, 1/10 W, METAL	70-145145	R785	100 KOHM, 1/10 W, METAL	70-144321
R467	47 KOHM, 1/10 W, METAL	70-145145	R786	22 KOHM, 1/10 W, METAL	70-144121
R470	22 KOHM, 1/10 W, METAL	70-144121	R787	100 OHM, 1/10 W, METAL	70-145136
R472	22 KOHM, 1/10 W, METAL	70-144121	R788	22 OHM, 1/10 W, METAL	70-144160
R502	220 OHM, 1/10 W, METAL	70-144194	R789	4.7 KOHM, 1/10 W, METAL	70-144123
R503	2.7 KOHM, 1/4 W, METAL	70-144293	R790	1 KOHM, 1/10 W, METAL	70-144125
R507	100 OHM, 1/8 W, METAL	70-144009	R791 B	1.5 KOHM, 1/10 W, METAL	70-144134
R508	100 OHM, 1/8 W, METAL	70-144009	R792	4.7 KOHM, 1/10 W, METAL	70-144123
R509	470 OHM, 1/10 W, METAL	70-144152	R793	47 KOHM, 1/10 W, METAL	70-145145
R510	470 OHM, 1/10 W, METAL	70-144152	R794	1.5 KOHM, 1/10 W, METAL	70-144134
R511	470 OHM, 1/10 W, METAL	70-144152	R795	47 KOHM, 1/10 W, METAL	70-145145
R512	100 KOHM, 1/10 W, METAL	70-144321	R796	22 KOHM, 1/10 W, METAL	70-144121
R513	100 KOHM, 1/10 W, METAL	70-144321	R797	5.6 KOHM, 1/10 W, METAL	70-144166
R515	33 OHM, 1/10 W, METAL	70-140320	R798	1 KOHM, 1/10 W, METAL	70-144125
R516	39 OHM, 1/10 W, METAL	70-144124	R799	2.7 KOHM, 1/10 W, METAL	70-144159
R517	1 KOHM, 1/10 W, METAL	70-144125	R811	22 KOHM, 1/10 W, METAL	70-144121
R518	1.5 KOHM, 1/10 W, METAL	70-144134	R812	22 KOHM, 1/10 W, METAL	70-144121
R520 A	180 OHM, 1 W, METAL	70-144221	R813	22 KOHM, 1/10 W, METAL	70-144121
R520 B	100 OHM, 1/10 W, METAL	70-144299	R814	22 KOHM, 1/10 W, METAL	70-144121
R701	220 OHM, 1/10 W, METAL	70-144194	R815	22 KOHM, 1/10 W, METAL	70-144121
R702	47 KOHM, 1/10 W, METAL	70-145145	R816	22 KOHM, 1/10 W, METAL	70-144121
R704	47 KOHM, 1/10 W, METAL	70-145145	R827	470 OHM, 1/10 W, METAL	70-144152
R705	47 KOHM, 1/10 W, METAL	70-145145	R831	47 KOHM, 1/10 W, METAL	70-145145
R706	2.2 KOHM, 1/10 W, METAL	70-144113	R832	47 KOHM, 1/10 W, METAL	70-145145
R707	220 OHM, 1/10 W, METAL	70-144194	R833	47 KOHM, 1/10 W, METAL	70-145145
R708	4.7 KOHM, 1/10 W, METAL	70-144123	R835	22 KOHM, 1/10 W, METAL	70-144121
R711	47 OHM, 1/10 W, METAL	70-145130	R845	1 KOHM, 1/10 W, METAL	70-144125
R713	10 KOHM, 1/10 W, METAL	70-144120	R846	1 KOHM, 1/10 W, METAL	70-144125
R714	22 KOHM, 1/10 W, METAL	70-144121	R847	1 KOHM, 1/10 W, METAL	70-144125
R715	22 KOHM, 1/10 W, METAL	70-144121	R848	1 KOHM, 1/10 W, METAL	70-144125
R716	22 KOHM, 1/10 W, METAL	70-144121	R849	1 KOHM, 1/10 W, METAL	70-144125
R717	150 OHM, 1/10 W, METAL	70-144321	R853	1 KOHM, 1/10 W, METAL	70-144125
R718	6.8 KOHM, 1/10 W, METAL	70-144158	R854	1 KOHM, 1/10 W, METAL	70-144125
R719	2.2 KOHM, 1/10 W, METAL	70-144113	R855	1 KOHM, 1/10 W, METAL	70-144125
R720	100 OHM, 1/10 W, METAL	70-145136	R858	0 OHM, 1/10 W, METAL	70-144106
R721	47 OHM, 1/10 W, METAL	70-145130	R859	10 KOHM, 1/10 W, METAL	70-144120
R722	47 OHM, 1/10 W, METAL	70-145130	R861	1 KOHM, 1/10 W, METAL	70-144125
R731	47 OHM, 1/10 W, METAL	70-145130	R863	1 KOHM, 1/10 W, METAL	70-144125
R732	6.8 KOHM, 1/10 W, METAL	70-145139	R864	22 KOHM, 1/10 W, METAL	70-144121
R733	10 KOHM, 1/10 W, METAL	70-144120	R865	1 KOHM, 1/10 W, METAL	70-144125
R734	22 KOHM, 1/10 W, METAL	70-144121	R866	10 KOHM, 1/10 W, METAL	70-144120
R735	22 KOHM, 1/10 W, METAL	70-144121	R867	22 KOHM, 1/10 W, METAL	70-144121
R736	22 KOHM, 1/10 W, METAL	70-144121	R868	10 KOHM, 1/10 W, METAL	70-144120
R737	150 OHM, 1/10 W, METAL	70-140321	R870	1 KOHM, 1/10 W, METAL	70-144125
R738	6.8 KOHM, 1/10 W, METAL	70-144139	R871	47 KOHM, 1/10 W, METAL	70-145145
R739	2.2 KOHM, 1/10 W, METAL	70-144113	R875	100 KOHM, 1/10 W, METAL	70-144321
R740	100 OHM, 1/10 W, METAL	70-145136	R878	100 KOHM, 1/10 W, METAL	70-144321
R741	47 OHM, 1/10 W, METAL	70-145130	R879	22 KOHM, 1/10 W, METAL	70-144121
R742	47 OHM, 1/10 W, METAL	70-145130	R880	10 KOHM, 1/10 W, METAL	70-144120
R743	1 KOHM, 1/10 W, METAL	70-144125	R881	1 KOHM, 1/10 W, METAL	70-144125
R751	47 KOHM, 1/10 W, METAL	70-145145	R882	1 KOHM, 1/10 W, METAL	70-144125
R752	47 KOHM, 1/10 W, METAL	70-145145	R883	22 KOHM, 1/10 W, METAL	70-144121
R754	6.8 KOHM, 1/10 W, METAL	70-144139	R884	1 KOHM, 1/10 W, METAL	70-144125
R755	2.2 KOHM, 1/10 W, METAL	70-144113	R885	3.9 KOHM, 1/10 W, METAL	70-145132
R756	100 OHM, 1/10 W, METAL	70-145136	R886	4.7 KOHM, 1/10 W, METAL	70-144123
R757	47 OHM, 1/10 W, METAL	70-145130	R888	1 MOHM, 1/10 W, METAL	70-144155
R758	1 KOHM, 1/10 W, METAL	70-144125	R889	1 KOHM, 1/10 W, METAL	70-144125
R759	3.3 KOHM, 1/10 W, METAL	70-144118	R891	22 KOHM, 1/10 W, METAL	70-144121
R760	47 OHM, 1/10 W, METAL	70-145130	R892	10 KOHM, 1/10 W, METAL	70-144120
R770	47 KOHM, 1/10 W, METAL	70-145145	R896	10 KOHM, 1/10 W, METAL	70-144120
R772	22 OHM, 1/10 W, METAL	70-144160	R897	100 KOHM, 1/10 W, METAL	70-144321
R773	100 KOHM, 1/10 W, METAL	70-144321			
R774	1 KOHM, 1/10 W, METAL	70-144125		VARIABLE RESISTORS,	
R776	47 KOHM, 1/10 W, METAL	70-145145			
R777	4.7 KOHM, 1/10 W, METAL	70-144123	RV241	RH0648C14	70-164122
R778	10 KOHM, 1/10 W, METAL	70-144120	RV301	RK0971111-10KB, CARBON	70-164067
R779	22 KOHM, 1/10 W, METAL	70-144121	RV401	RH062KC15 (100K)	70-164110
R780	0 OHM, 1/10 W, METAL	70-144106	RV402	RH064JC14 (10K)	70-164122
R782	4.7 KOHM, 1/10 W, METAL	70-144123	RV403	RH064JC47KB (47K)	70-164123

PARTS

70-1336

TR-1519 BOARD (Continued)

REF NO.	DESCRIPTION	PART NO.	REF NO.	DESCRIPTION	PART NO.
CRYSTALS			MISCELLANEOUS (CONTINUED)		
X101	XTAL, HC-431U, 12.8 MHz	70-128111	CM701	IL-S-2P-S2T2-EF	70-158399
X241	TXAL UM-1 44,545 MHz	70-128098	F501	ICP-N50	70-204079
X901	XTAL, AT-51 8.000 MHz	70-123114	P304	CABLE ASSY ILG-2S-S3C2	70-034624
MISCELLANEOUS			P305	CABLE ASSY IL-S-3S, L=70	70-034784
	SHIELD CASE	70-089339	RC901	RC90191 CRB602	70-086073
	INSULATION PLATE	70-157357	RC902	RC90201 CRB402	70-086074
	LED ASSY CX-103	70-202077	S301	PUSH SWITCH SPUP19F	70-183122
	CABLE JUMPER	70-034785	S303	PUSH SWITCH SPUP19F	70-183122
	SPACER	70-150290	S305	PUSH SWITCH SPUP19F	70-183122
CM201	IL-S-2P-S2T2-EF	70-158399	S306	SWITCH SSSJ12	70-183123
			S307	PUSH SWITCH SPUP19F	70-183122
			SP301	SPEAKER	70-060037

REPLACEMENT PARTS ORDERING

To speed delivery and avoid errors, always include the following information when ordering replacement parts:

1. Best identification of the parts.
 - A. MIDLAND part number, or
 - B. Model and Serial numbers of equipment in which the part is used, with
 - C. Part description, and
 - D. Schematic reference designator, and,
 - E. If necessary, return the old part as sample.
2. Specify quantity desired of each part.
3. Ship-to address (and billing address if different).

Mail or phone your order to:

MIDLAND INTERNATIONAL CORPORATION
1690 North Topping Avenue
Kansas City, Missouri 64120
(816) 241-8500



1690 NORTH TOPPING • KANSAS CITY • MISSOURI • 64120
(P.O. BOX 419903 • KANSAS CITY • MISSOURI • 64141)
TELEPHONE: (816) 241-8500 • FAX: (816) 245-1144

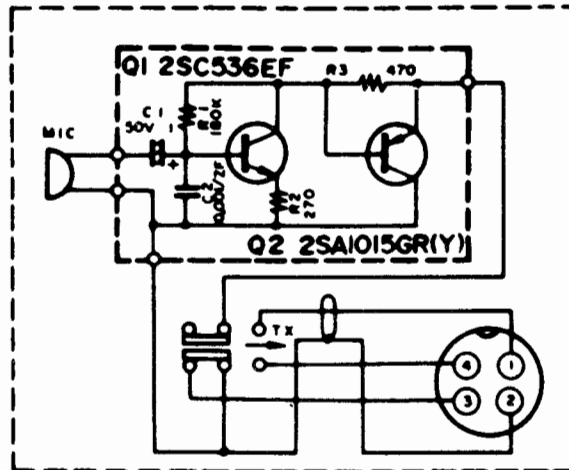

MICROPHONE PARTS LIST

DESCRIPTION:

PART NUMBER:

L.M.R. Dynamic Mic	70-038013
Panel, Case Front Mic	70-010072
Plate, Name Front Panel	70-020022
Case Front	70-010073
Element, Dynamic	70-038004
P/T Switch	70-183004
P/T Knob	70-118007
P.C.B. W/Comp.	70-075014
P.C.B. W/O Comp.	70-070008
2SA 1015	70-080025
2SC536	70-080026
Elect Cap 10F 50 WV	70-135002
Ceramic Cap (102)	70-132005
Cushion, P/T Switch	70-157015
Resistor 270 ohm 1/4 W	70-141010
Resistor 470 ohm 1/4 W	70-141016
Resistor 170K 1/4 W	70-141037
Cord, Mic W/O Cont.	70-034074
Cord, Mic W/Cont.	70-034075
Plug Mic 4 Pin	70-159015
Case Mic Rear	70-013017
Rubber, Mic Case Rear	70-157016
Screw, Case	70-151076
Screw, Mic Button	70-151078
Screw, Front Panel	70-151077
Mic Button	70-118008
Washer Special Mic Button	70-151079
Plate, Case Rear	70-020024
Weight, Ballast	70-151369